

SIMATIC

FM 351 Positioning Module

Manual

This manual is part of the documentation package with the order number:

6ES7351-1AH00-8BG0

**03/2000
C79000-G7076-C351
Edition 02**

Preface, Contents

User Information

Product Overview **1**

Basics of Positioning **2**

Installing and Removing the FM 351 **3**

Wiring the FM 351 **4**

Installing the Configuration Package **5**

Programming the FM 351 **6**

Putting the FM 351 into Operation **7**

Reference Information

Machine Data and Increments **8**

Modes and Jobs **9**

Encoders **10**

Diagnostics **11**

Samples **12**

Appendix

Technical Specifications **A**

Connection Diagrams **B**

Data Blocks, Error Classes **C**

Index

Notes on Safety



Danger

indicates that death, severe personal injury or substantial property damage **will** result if proper precautions are not taken.



Warning

indicates that death, severe personal injury or substantial property damage **can** result if proper precautions are not taken.



Caution

indicates that minor personal injury or property damage can result if proper precautions are not taken.

Note

draws your attention to particularly important information on the product, handling the product, or to a particular part of the documentation.

Qualified Personnel

Only **qualified personnel** should be allowed to install and work on this equipment. Qualified persons are defined as persons who are authorized to commission, to ground, and to tag circuits, equipment, and systems in accordance with established safety practices and standards.

Correct Usage

Note the following:



Warning

This device and its components may only be used for the applications described in the catalog or the technical description, and only in connection with devices or components from other manufacturers which have been approved or recommended by Siemens.

This product can only function correctly and safely if it is transported, stored, set up, and installed correctly, and operated and maintained as recommended.

Trademarks

SIMATIC®, SIMATIC HMI® and SIMATIC NET® are registered trademarks of SIEMENS AG.

Third parties using for their own purposes any other names in this document which refer to trademarks might infringe upon the rights of the trademark owners.

Copyright © Siemens AG 1996 All rights reserved

The reproduction, transmission or use of this document or its contents is not permitted without express written authority. Offenders will be liable for damages. All rights, including rights created by patent grant or registration of a utility model or design, are reserved.

Siemens AG
Bereich Automatisierungs- und Antriebstechnik
Geschäftsgebiet Industrie-Automatisierungssysteme
Postfach 4848, D- 90327 Nürnberg

Siemens Aktiengesellschaft

Disclaimer of Liability

We have checked the contents of this manual for agreement with the hardware and software described. Since deviations cannot be precluded entirely, we cannot guarantee full agreement. However, the data in this manual are reviewed regularly and any necessary corrections included in subsequent editions. Suggestions for improvement are welcomed.

© Siemens AG 1996
Subject to technical change.

C79000-G7076-C351



Preface

Validity of the Manual

This manual contains the description of the FM 351 positioning module valid at the time of publication. We reserve the right to describe modifications in the functionality of the FM 351 in a product information bulletin.

The manual with the number in the footer is valid for the FM 351	
	Order number	Revision level
EWA 4NEB 720 6001-02	6ES7 351-1AH00-0AE0 6ES7 351-1AH01-0AE0	1 = $\begin{array}{c c} X & 2 \\ \hline 3 & 4 \end{array}$ 2 = $\begin{array}{c c} X & 3 \\ \hline 4 & 5 \end{array}$
C79000-G7000-C351-02	6ES7 351-1AH01-0AE0	3 = $\begin{array}{c c} X & 4 \\ \hline 5 & 6 \end{array}$

Content of the Manual

This manual describes the hardware and software of the FM 351 positioning module.

It consists of the following:

- A section describing basic aspects (Chapters 1 to 7)
- A reference section (Chapters 8 to 12)
- An appendix (Chapters A, B and C)
- An index.

CE Mark

Our products meet the requirements of the EU directive 89/336/EEC "Electromagnetic Compatibility" and the harmonized European standards (EN) listed in the directive.



In compliance with the above mentioned EU directive, Article 10, the conformity declarations are available to the relevant authorities at the following address:

Siemens Aktiengesellschaft
Bereich Automatisierungstechnik
A&D AS E 48
Postfach 1963
D-92209 Amberg

Further Support

If you have questions about using the products described in the manual and you cannot find the answers here, please contact your local Siemens representative. You will find the addresses, for example, in the appendix "SIEMENS Worldwide" in the manual:

S7-300 Programmable Controller, Installation.

If you have any questions or comments on this manual, please fill out the remarks form at the end of the manual and return it to the address shown on the form. We would be grateful if you could take the time to answer the questions giving your own personal opinion of the manual.

To help you to become familiar with working with SIMATIC S7 PLCs, we offer a range of courses. Please contact your regional training center or the central training center in D-90027 Nuremberg, Tel. +49 911/895-3202 for more information.

Up to the Minute Information

You can obtain the latest information on SIMATIC products from the following sources:

- on the **Internet** at <http://www.ad.siemens.de/>

SIMATIC Customer Support also provides you with the latest information and downloads that will help you use SIMATIC products:

- on the **Internet** at <http://www.ad.siemens.de/simatic-cs>
- From the SIMATIC Customer Support Mailbox at the number +49 (911) 895-7100

To dial the mailbox, use a modem with up to V.34 (28.8 kbauds), with the following parameter settings:
8, N, 1, ANSI, or dial via ISDN (x.75, 64 Kbps).

SIMATIC Customer Support is available at the phone and fax numbers and at the E-mail addresses listed below. You can also contact us via Internet mail or mail at the mailbox mentioned above.

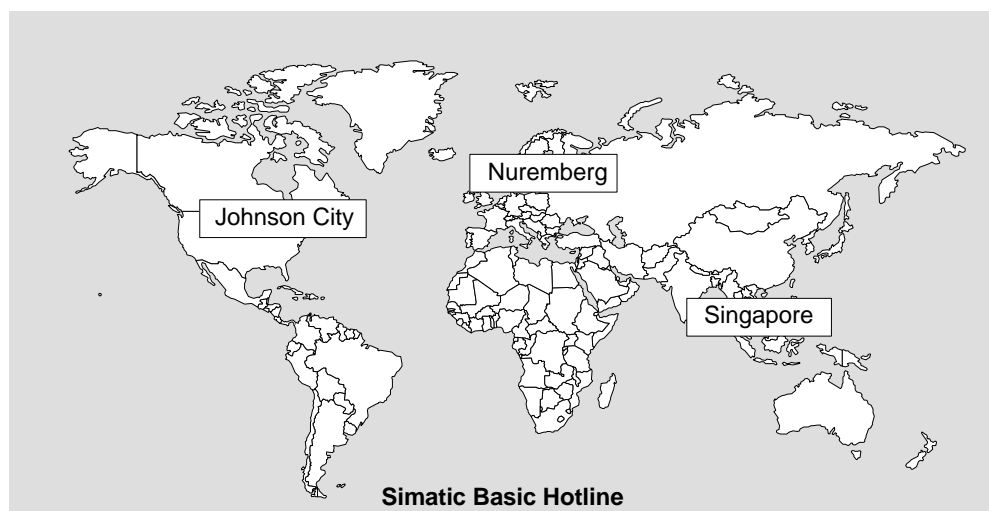
**Nuremberg****SIMATIC BASIC Hotline**

Local time: Mo.-Fr. 8:00 to 18:00

Phone: +49 (911) 895-7000

Fax: +49 (911) 895-7002

E-mail: simatic.support@nbgm.siemens.de**Johnson City****SIMATIC BASIC Hotline**

Local time: Mo.-Fr. 8:00 to 17:00

Phone: +1 423 461-2522

Fax: +1 423 461-2231

E-mail: simatic.hotline@sea.siemens.com**Singapore****SIMATIC BASIC Hotline**

Local time: Mo.-Fr. 8:30 to 17:30

Phone: +65 740-7000

Fax: +65 740-7001

E-mail: simatic@sae.siemens.com.sg**SIMATIC Premium Hotline**

(Calls charged, only with SIMATIC Card)

Time: Mo.-Fr. 0:00 to 24:00

Phone: +49 (911) 895-7777

Fax: +49 (911) 895-7001

The languages spoken on the hotlines are generally German and English. On the authorization hotline, French, Italian and Spanish are also available.

Contents

1	Product Overview	1-1
1.1	What is the FM 351?	1-2
1.2	Areas of Application of the FM 351	1-3
1.3	Setup for Controlled Positioning with an FM 351	1-4
2	Basics of Positioning	2-1
2.1	Controlled Positioning	2-2
2.2	Ranges and Switching Points of the FM 351	2-2
3	Installing and Removing the FM 351	3-1
4	Wiring the FM 351	4-1
4.1	Description of the Encoder Interface	4-2
4.2	Connecting the Encoders	4-3
4.3	Description of the Front Connector	4-4
4.4	Wiring the Power Unit	4-7
4.5	Wiring the Front Connector	4-9
5	Installing the Configuration Package	5-1
6	Programming the FM 351	6-1
6.1	Basics of Programming an FM 351	6-2
6.2	FC ABS_INIT (FC0)	6-4
6.3	FC ABS_CTRL (FC1)	6-5
6.4	FC ABS_DIAG (FC2)	6-11
6.5	Data Blocks	6-13
6.5.1	Templates for Data Blocks	6-13
6.5.2	Channel DB	6-13
6.5.3	Diagnostic DB	6-14
6.5.4	Parameter DB	6-14
6.6	Technical Specifications of the FCs and DBs for the FM 351	6-15
6.7	Fast Access to Module Data	6-17
6.8	Parameter Transfer Routes	6-19

7	Putting the FM 351 into Operation	7-1
8	Machine Data and Incremental Dimensions	8-1
8.1	Writing and Reading Machine Data and Incremental Dimension Tables	8-2
8.2	System of Units	8-5
8.3	Machine Data for the Drive	8-6
8.4	Machine Data for the Axis	8-12
8.5	Machine Data for the Encoder	8-15
8.6	Absolute Encoder Adjustment	8-19
8.7	Resolution	8-22
8.8	Incremental dimensions	8-24
8.8.1	Incremental dimension number 1 to 100	8-24
8.8.2	Incremental Dimension Number 254	8-25
8.8.3	Incremental Dimension Number 255	8-26
9	Modes and Jobs	9-1
9.1	End of Positioning	9-2
9.2	Jogging Operating Mode	9-8
9.3	Reference Point Approach Mode	9-11
9.4	Incremental Operating Mode	9-17
9.5	Set Actual Value / Cancel Set Actual Value	9-23
9.6	Set Reference Point	9-25
9.7	Loop Traverse	9-27
9.8	Enable input	9-30
9.9	Read Position Data	9-31
9.10	Read Encoder Data	9-32
9.11	Return Signals for Positioning	9-33
9.12	Return Signals for Diagnostics	9-34
10	Encoders	10-1
10.1	Incremental Encoders	10-2
10.2	Absolute Encoders	10-4
11	Diagnostics	11-1
11.1	Options for Displaying and Evaluating Errors	11-2
11.2	Types of Error	11-2
11.2.1	Synchronous Errors	11-2
11.2.2	Asynchronous Errors	11-2
11.3	Meaning of the Error LEDs	11-3
11.4	Displaying Errors on an OP	11-4

11.5	Error Evaluation in the User Program	11-5
11.6	Diagnostic Buffer of the Module	11-10
11.7	Diagnostic Interrupts	11-11
12	Samples	12-1
12.1	Introduction	12-2
12.2	Requirements	12-2
12.3	Preparing the Samples	12-3
12.4	Code of the Samples	12-3
12.5	Testing a Sample	12-4
12.6	Adapting a Sample	12-4
12.7	Sample Program 1 "GettingStarted"	12-5
12.8	Sample Program 2 "Commission"	12-7
12.9	Sample Program 3 "AllFunctions"	12-9
12.10	Sample Program 4 "OneChannel"	12-11
12.11	Sample Program 5 "DiagnosticAndInterrupt"	12-14
12.12	Sample Program 6 "MultiChannels"	12-16
A	Technical Specifications	A-1
B	Connection Diagrams	B-1
B.1	Connection Diagram for Incremental Encoder Siemens 6FX 2001-2 (Up=5V; RS 422)	B-2
B.2	Connection Diagram for Incremental Encoder Siemens 6FX 2001-2 (Up=24V; RS 422)	B-3
B.3	Connection Diagram for Incremental Encoder Siemens 6FX 2001-4 (Up=24V; HTL)	B-4
B.4	Connection Diagram for Absolute Encoder Siemens 6FX 2001-5 (Up=24V; SSI)	B-5
C	Data Blocks/Error Lists	C-1
C.1	Content of the Channel DB	C-2
C.2	Content of the Parameter DB	C-9
C.3	Data and Structure of the Diagnostic DB	C-11
C.4	List of JOB_ERR Messages	C-13
C.5	Error Classes	C-15
	Index	Index-1

Product Overview

1

Chapter Overview

Section	Topic	Page
1.1	What is the FM 351?	1-2
1.2	Areas of Application of the FM 351	1-3
1.3	Setup for Controlled Positioning with an FM 351	1-4

1.1 What is the FM 351?

The FM 351 positioning module is used in the S7-300 programmable logic controller (PLC) for controlled positioning with rapid/creep feed speeds. The module has two independent channels each of which can control a rotary or linear axis. Each channel of the module supports an incremental or absolute encoder (SSI).

You can operate a number of FM 351 positioning modules simultaneously. Combinations with other FM/CP modules are also possible. A typical application is the combination with an FM 352 electronic cam controller.

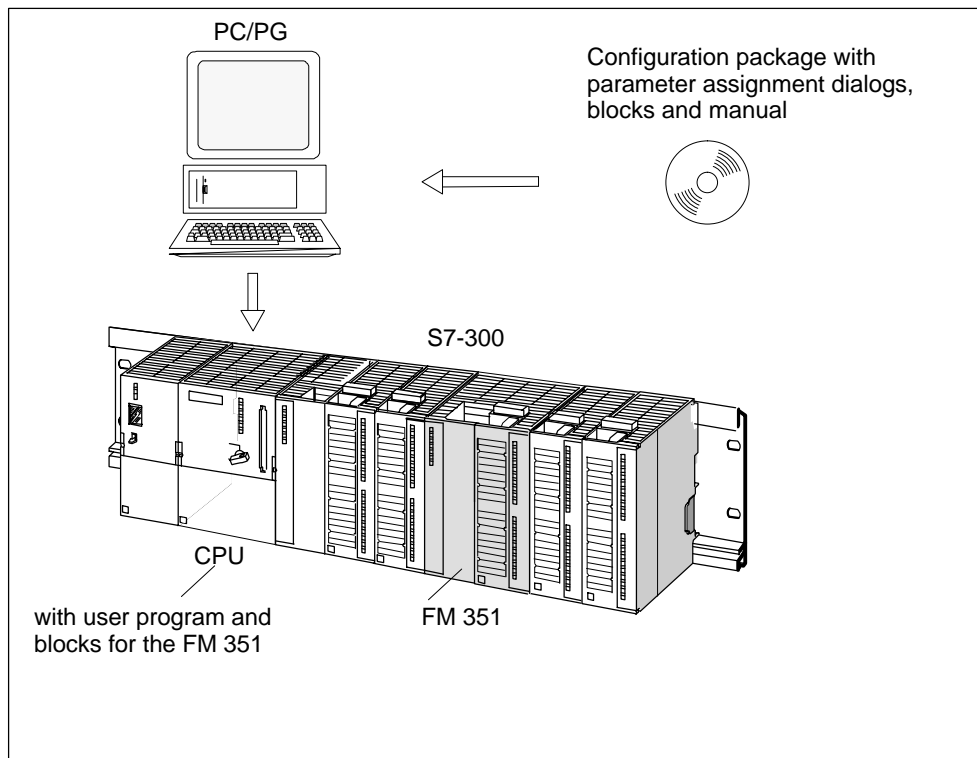

Figure 1-1 Structure of a SIMATIC S7-300 PLC with an FM 351

1.2 Areas of Application of the FM 351

- Packing machines
- Lifting and transport equipment
- Woodworking machines

Example: Control of feed operations

Various wooden parts are processed with a profile machine. Various operations and cutters are required to process the wood. The various cutters are changed by controlled positioning operations.

- Paper and printing machines
- Rubber and plastics processing machines

Example: Simple handling

The molded parts in an injection molding machine are removed from the mold by a grab arm. The arm is controlled by the positioning module.

- Building materials industry
- Machine tools

1.3 Setup for Controlled Positioning with an FM 351

Control Circuit

Figure 1-2 illustrates the components of a controlled positioning setup with rapid/creep speed drives.

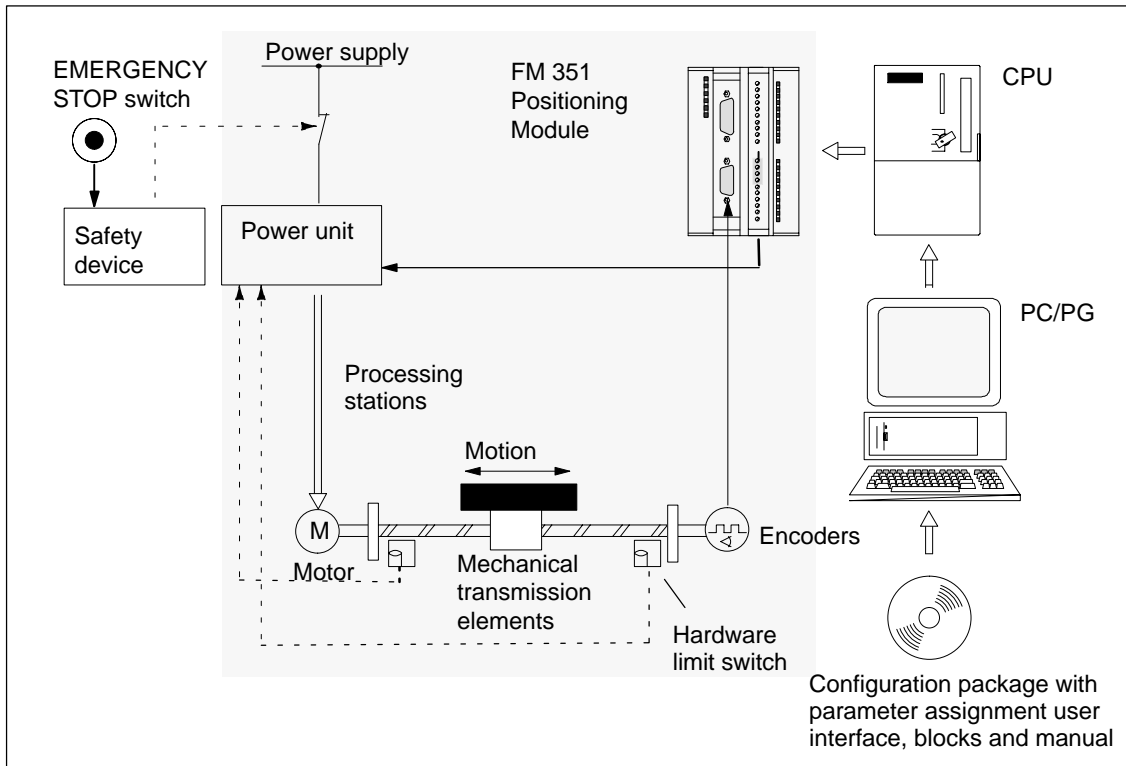

Figure 1-2 Controlled Positioning

Power Unit and Safety Device

The power unit (for example a contactor combination) is activated via the digital outputs of the FM 351. The FM 351 has four control modes (see Section 8.3, page 8-6).

If the safety device responds, (EMERGENCY OFF switch or hardware limit switch), the power unit turns off the motor.

Motor

The motor is controlled by the power unit and drives the axis.

Encoders

The encoder supplies information both about position and direction. The following encoders can be connected:

- Incremental encoders with 5 V differential signals, symmetrical
- Incremental encoders with 24 V signals, asymmetrical
- SSI absolute encoders

FM 351 Positioning Module

The FM 351 can position up to two axes automatically using rapid/creep feed.

The power unit is controlled via four digital outputs (see Section 8.3, page 8-6).

The FM 351 positioning module calculates the current actual position value of the axis from the encoder signals that are proportional to the distance moved (see Section 8.5, page 8-15 and Section 8.7, page 8-22).

The FM 351 provides the following modes and functions:

- “Jogging” (see Section 9.2, page 9-8).
- “Reference point approach” (see Section 9.3, page 9-11).
- “Absolute/relative incremental approach” (see Section 9.4, page 9-17).
- Set actual value (see Section 9.5, page 9-23).
- Set reference point (see Section 9.6, page 9-25).
- Loop traverse (see Section 9.7, page 9-27).

CPU

The CPU executes the user program. Data and signals are exchanged between the user program and the module using function calls.

PC/PG

The PC/programming device is used for the following:

- Parameter assignment: You make the parameter settings for the FM 351 either with the *parameter dialogs* or using the parameter DB (see Section 6.5.4, page 6-14).
- Programming: You program the FM 351 with functions that you incorporate directly in your user program.
- Testing and commissioning: You test the FM 351 and commission it using the *parameter dialogs*.

Overview of the Positioning Module

- **Two axes, axis types:**
 - linear axis
 - rotary axis
- **Four digital outputs per axis**
- **Four digital inputs per axis**
- **Typical drives/motors:**
 - Standard motor, contactor controlled
 - Standard motor with frequency converter (example Micromaster)
 - Asynchronous motor connected to power unit with vector control.
- **Positioning systems:**
 - Incremental encoder 5 V, symmetrical
 - Incremental encoder 24 V, asymmetrical
 - SSI absolute encoders
- **Monitoring functions:**
 - Working range monitoring with software limit switches
 - Stationary state monitoring
 - Encoder monitoring
 - Monitoring of axis movement and final target approach
- **System environment:**
 - Central use
SIMATIC S7-300, CPU 314 or higher (recommendation: dependent on the application and user memory requirements)
SIMATIC C7
 - Distributed use with ET 200M
- **System integration:**
 - Module exchange without PG possible
 - Teleservice possible

Basics of Positioning

2

Chapter Overview

Section	Topic	Page
2.1	Controlled Positioning	2-2
2.2	Ranges and Switching Points of the FM 351	2-2

2.1 Controlled Positioning

Each positioning operation is characterized by the following:

- a start position
- a target to which the tool will move, and
- parameters determining how the positioning operation is executed.

The target position is first approached at high speed (rapid speed).

At a specified distance from the target position the speed is reduced to a lower speed (creep speed). Shortly before the axis reaches the target position, again at a specified distance from the target position, the drive is switched off. The module then monitors the final target approach.

The drive is controlled via digital outputs that set the rapid or creep speed and the required direction (see Section 8.3, page 8-6).

2.2 Ranges and Switching Points of the FM 351

Target

The target is the absolute or relative position on the axis that is approached during a positioning operation.

Definition of the Switching Points and Ranges

The following ranges and positions can be set for each positioning operation:

Range	Explanation
Working range	Defines the range that you set for your task using the software limit switches or the end of the rotary axis.
Switchover difference	Defines the distance to the target at which the drive switches from rapid speed to creep speed.
Switchover point	Defines the position at which the drive changes from rapid speed to creep speed.
Switch-off difference	Defines the distance to the target at which the drive is turned off.
Switch-off point	Defines the position at which the drive is turned off. From this point onwards, the FM 351 activates monitoring functions.
Target range	Defines the positioning accuracy of your application and is located symmetrically either side of the target.
Stationary range	Defines a symmetrical range around the target that is monitored by the FM 351.

Figure 2-1 shows a possible arrangement of the switching points and differences for a positioning operation. To simplify the illustration, it is assumed that the change in actual speed is linear over the distance traveled. The ramps that result, are due to mechanical inertia or due to the parameter settings for the power unit.

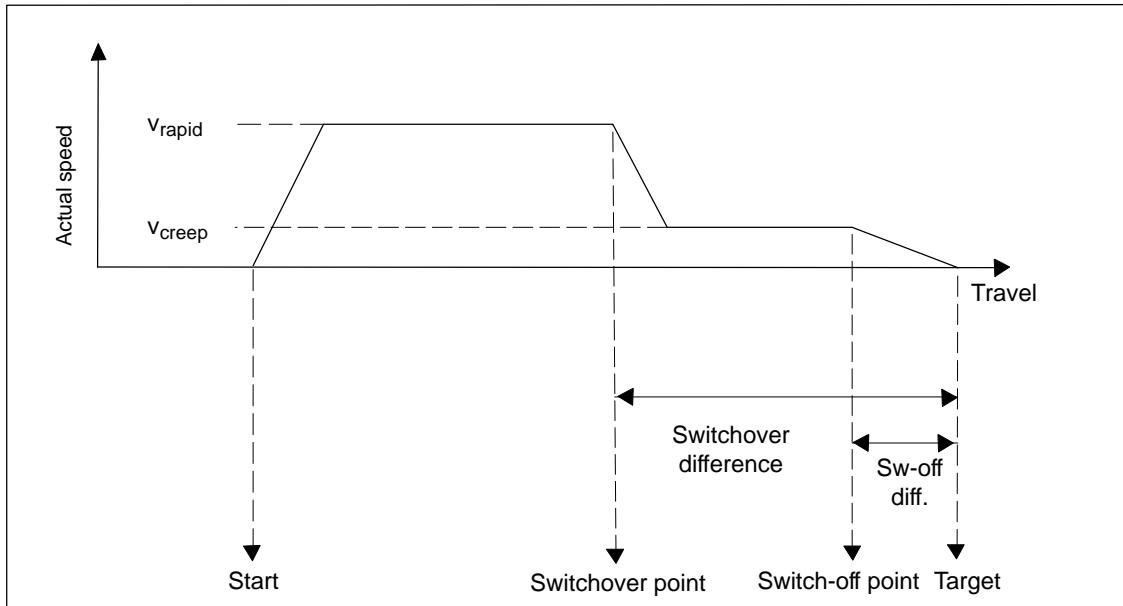

Figure 2-1 Switching Points and Differences

Figure 2-2 illustrates how the switching ranges can be arranged around the target.

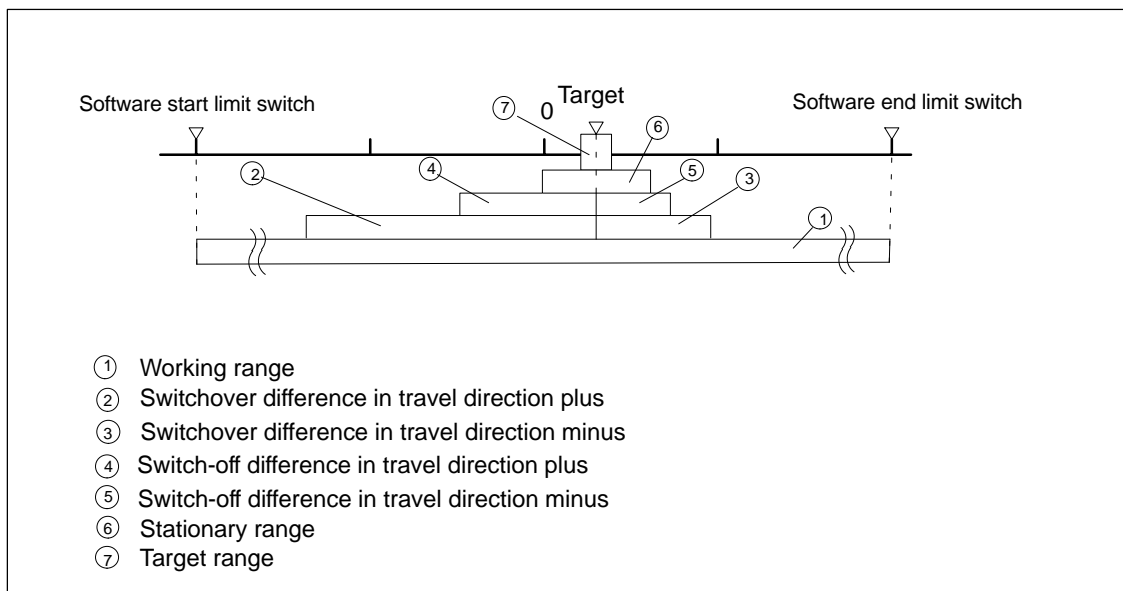

Figure 2-2 Switching Ranges Around a Target

Installing and Removing the FM 351

Important Safety Rules

When integrating an S7-300 with an FM 351 in a plant or system, there are important rules and regulations that are described in the installation manual *S7-300 Programmable Controller, Hardware and Installation*.

Installation of the Rail

Horizontal installation of the rail is preferable.

If you install the rail vertically, remember the restrictions regarding the ambient temperature (max. 40 °C).

Selecting Slots

The FM 351 can be installed in any slot for signal modules on the rail.

Required Tools

To install or remove the FM 351, you require a 4.5 mm screwdriver.

Installing the FM 351 Positioning Module

1. The FM 351 is supplied with a bus interconnector. Plug this onto the bus connector of the module to the left of the FM 351. (The bus connector is on the back of the module and you may need to loosen the module again first).
2. If further modules are installed to the right, first plug the bus interconnector of the next module onto the right bus connector of the FM 351.

If the FM 351 is the last module in the tier, do not attach a bus interconnector!

3. Fit the FM 351 onto the rail from above and push it in from below.
4. Secure the FM 351 with screws (torque approximately 0.8 to 1.1 Nm).
5. After installation, you can assign a slot number to the FM 351. Slot labels are supplied with the CPU.

The numbering scheme and numbering of slots and how to insert the slot labels is described in the installation manual *S7-300 Programmable Controller, Hardware and Installation*.

6. Fit the shield contact element.

Order no.: 6ES7 390-5AA00-0AA0

Removing the FM 351 Positioning Module

1. Turn off the power controller.
2. Turn off the 24 V supply for the FM 351.
3. Switch the CPU to STOP.
4. Open the front hinged panels.
Remove any labeling strips.
5. Unlock the front connector and remove it.
6. Remove the D sub connector to the encoder.
7. Loosen the securing screws on the module.
8. Tilt the module upwards and remove it from the rail.

Wiring the FM 351

4

Chapter Overview

Section	Topic	Page
4.1	Description of the Encoder Interface	4-2
4.2	Connecting the Encoders	4-3
4.3	Description of the Front Connector	4-4
4.4	Wiring the Power Unit	4-7
4.5	Wiring the Front Connector	4-9

Important Safety Rules

It is essential for the safety of the system to install the elements listed below and to adapt them to your system.

- EMERGENCY STOP switch with which you can turn off the entire system.
- Hardware limit switches that directly influence the power units of all drives.
- Motor circuit-breaker.

4.1 Description of the Encoder Interface

Location of the Sub-D Connectors

Figure 4-1 shows the location and labeling of the female connectors on the module. You can connect incremental or absolute encoders (SSI) to the two sub-D female connectors (see Section 10).

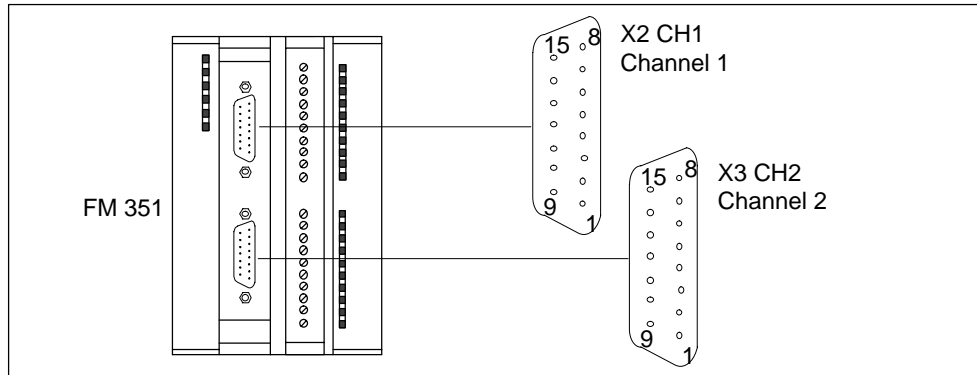

Figure 4-1 Location of the Sub-D Connectors X2 and X3

Pinout of the Female Connectors X2 and X3

Pin	Name	Incr. Encoder (24V)	Incr. Encoder (5V)	Absolute Encoders
1	A*	Encoder signal A	---	---
2	CLS	---	---	SSI clock signal
3	$\overline{\text{CLS}}$	---	---	SSI clock signal inv.
4	B*	Encoder signal B	---	---
5	DC 24V	Encoder power	Encoder power	Encoder power
6	DC 5.2V	---	Encoder power	Encoder power
7	M	Ground	Ground	Ground
8	N*	Zero marker signal	---	---
9	RE	Sourcing/sinking (see Sec. B.3)	---	---
10	N	---	Zero marker signal	---
11	$\overline{\text{Z}}$	---	Zero marker signal inv.	---
12	$\overline{\text{B}}$	---	Encoder signal B inv.	---
13	B	---	Encoder signal B	---
14	$\overline{\text{A}} / \overline{\text{DAT}}$	---	Encoder signal A inv.	SSI data inv.
15	A / DAT	---	Encoder signal A	SSI data

4.2 Connecting the Encoders

Shield Contact Element

Using the shield contact element, you can connect all shielded cables with ground simply and easily making use of the direct connection between the shield contact element and the rail. For more detailed information, refer to the manual *S7-300 Programmable Controller, Hardware and Installation*.

Procedure

Follow the steps outlined below to connect the encoder:

1. Connect the cable to the encoder.

With some encoders it may be necessary to assemble the cable (at the encoder end) according to the manufacturer's specifications.
2. The encoder cables must be shielded.
3. The leads A and \bar{A} , B and \bar{B} , N and \bar{N} of an incremental encoder or the leads DAT and \bar{DAT} , CLS and \bar{CLS} of an absolute encoder must be twisted in pairs.
4. Open the front panel and plug the sub D connector into the FM 351.
5. Secure the connector with the knurled screws. Close the front panel.
6. Remove the insulation from the cable and clamp the cable shield into the shield contact element. Use shield clamps.

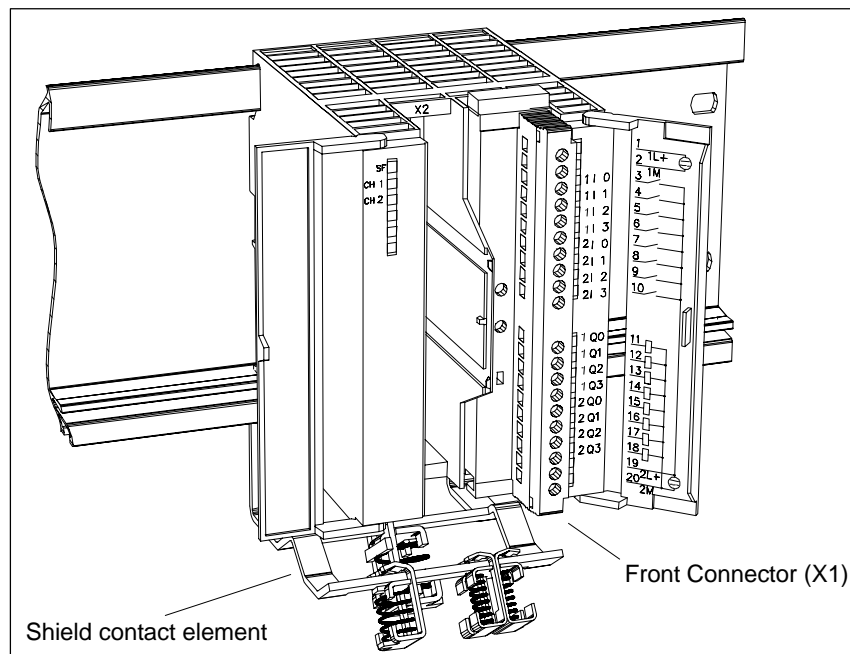

Figure 4-2 Location of the Shield Contact Element

4.3 Description of the Front Connector

Front Connector

You connect the power supplies of the encoder and the digital outputs at the 20-pin front connector (see Figure 4-2). The digital outputs and inputs assigned to the channels are also connected.

Pinout of the Front Connector (X1)

Terminal	Name	Meaning	Incremental Encoders	Absolute Encoders
1	1L+	24 V DC auxiliary supply for the encoders		
2	1M	Encoder power supply ground		
3	1I0	Channel 1: Digital input 0	Reference-point switch	Not used
4	1I1	Channel 1: Digital input 1	Reverse switch	Not used
5	1I2	Channel 1: Digital input 2	Enable input	
6	1I3	Channel 1: Digital input 3	Not used	
7	2I0	Channel 2: Digital input 0	Reference point switch	Not used
8	2I1	Channel 1: Digital input 2	Reverse switch	Not used
9	2I2	Channel 2: Digital input 2	Enable Input	
10	2I3	Channel 2: Digital input 3	Not used	
11	1Q0	Channel 1: Digital output 0		
12	1Q1	Channel 1: Digital output 1		
13	1Q2	Channel 1: Digital output 2		
14	1Q3	Channel 1: Digital output 3		
15	2Q0	Channel 2: Digital output 0		
16	2Q1	Channel 2: Digital output 1		
17	2Q2	Channel 2: Digital output 2		
18	2Q3	Channel 2: Digital output 3		
19	2L+	24 V DC auxiliary supply for the load current		
20	2M	Load power supply ground		

Auxiliary Power Supply for the Encoders (1L+, 1M)

Here, you connect the 24 V DC auxiliary power for the encoders. The reference potential of this power supply (1M) is not connected with the chassis of the load current supply (2M) in the FM 351.

The 24 V DC auxiliary power for the encoders is monitored for undervoltage and chassis wire break.

The 24 V DC auxiliary voltage for the encoders is converted internally to 5.2V DC. This means that 24 V DC and 5.2 V DC are available on the encoder interface (sub D female connector X2 and X3) for the different types of encoders.



Caution

Make sure that the polarity of the 24 V DC auxiliary power supply for the encoders (1L+, 1M) is correct.

If you connect the 24 V DC auxiliary power supply for the encoders and accidentally reverse the polarity, this will damage the module to such an extent that it must be replaced.

Auxiliary Power Supply for the Load Current (2L+, 2M)

You connect a 24 V auxiliary supply for the load current of the digital outputs at terminals 2L+ and 2M.



Caution

Make sure that the polarity of the 24 V auxiliary power for the load current (2L+, 2M) is correct.

If you connect the 24 V DC auxiliary power for the load current and accidentally reverse the polarity, this will damage the module to such an extent that it must be replaced.

Note on Wiring 24 V DC

When wiring up the module, remember that the terminals 1L+,1M and 2L+, 2M must be connected for the module to operate correctly.

If you connect 1L+, 1M and 2L+, 2M to separate power supplies, the synchronization of the axes is retained if there is an outage of the auxiliary power supply for the load current.

Load Current Supplies

The DC power supply for the load current must meet the following requirements:

Only low voltage ≤ 60 V DC safety isolated from the power supply network must be used for the load current supply. Safe isolation can be implemented, for example, by adhering to the specifications in VDE 0100 Part 410 / HD 384-4-41 / IEC 364-4-41 (as functional low voltage with safe isolation) or VDE 0805 / EN 60950 / IEC 950 (as safety extra low voltage SELV) or VDE 0106 Part 101.

8 Digital Inputs (1I0 to 2I3)

The FM 351 has 4 digital inputs per channel.

You can connect bounce-free switches (24 V current sourcing) or non-contact sensors (2 or 3-wire proximity switches) to the 8 digital inputs.

The digital inputs are not monitored for short-circuits or wire break and are isolated from the chassis of the encoder supply and the chassis of the CPU.

A separate LED indicates the state of each input.

8 Digital Outputs (1Q0 to 2Q3)

The FM 351 has 4 digital outputs per channel.

The digital outputs are used to control the power unit. The function of the digital outputs depends on the control mode. The control mode (see Section 8.3, page 8-6) is selected in the configuration software or in the parameter DB.

The digital outputs are not monitored for short-circuits or wire break and are isolated from the chassis of the encoder supply and the chassis of the CPU.

A separate LED indicates the state of each output.

Table 4-1 Functions of the Digital Outputs, x for Channel 1 or 2

Output Q	Control Mode			
	1	2	3	4
xQ0	Rapid speed	Rapid/creep speed	Rapid speed	Rapid traverse plus
xQ1	Creep speed	Position reached	Creep speed	Creep speed plus
xQ2	Travel plus	Travel plus	Travel plus	Rapid traverse minus
xQ3	Travel minus	Travel minus	Travel minus	Creep speed minus

4.4 Wiring the Power Unit

Power Unit

The power unit (for example a simple contactor combination) is connected to the digital outputs of the FM 351 and controls the motor.

Contactor Circuit

Figure 4-3 shows the control and load current circuits of a power unit. The functions of the digital outputs correspond to control mode 1 (see Section 8.3, page 8-6).

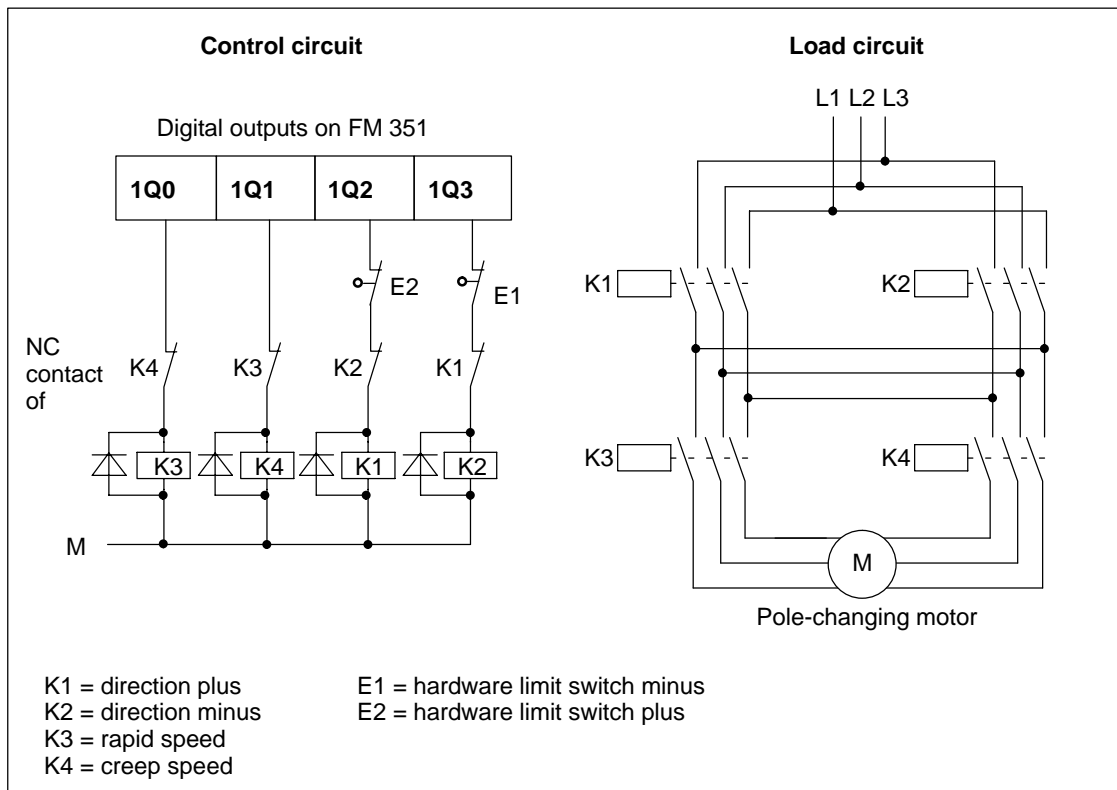

Figure 4-3 Contactor Circuit

How the Contactor Circuit Works

Contactors K1 and K2 control the direction of the motor. The contactors are interlocked by the normally closed contacts K2 and K1. The hardware limit switches E1 and E2 are the limit switches minus/plus. If the axis travels beyond these limit switches, the motor (direction) is turned off.

The contactors K3 and K4 switch the motor from rapid to creep speed. The contactors are interlocked by the normally closed contacts K4 and K3.



Caution

Interlock the power network contactors.

Interlocking of the contactors is shown in Figure 4-3.

If you do not keep to this rule, a short circuit can occur in the main power network.

Note

Direct connection of inductive components (for example relays and contactors) is possible without external wiring.

If SIMATIC output power circuits can be turned off by additionally installed contacts (for example relay contacts), you must include additional surge protection with inductive components (an example of surge protection is shown below).

Example of Surge Protection

Figure 4-4 illustrates an output circuit that requires additional surge voltage protection. Diodes or Z diodes are used with coils activated by direct current.

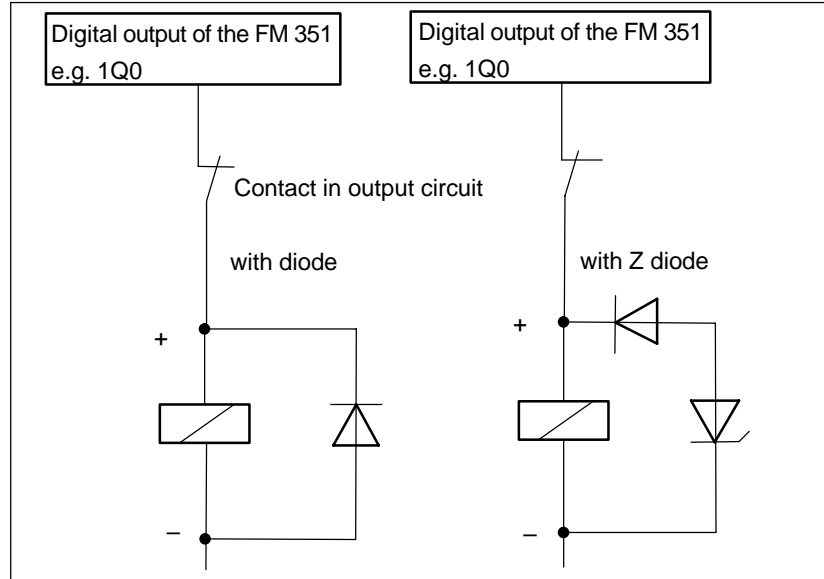

Figure 4-4 Relay in the Output Circuit

4.5 Wiring the Front Connector

Connecting Cords

- The cords for digital inputs and digital outputs must be shielded if they exceed a length of 100 m.
- The shields of the cords must be grounded at both ends.
- Flexible cord, cross section 0.25 to 1.5 mm²
- Wire-end ferrules are not required. If, however, you prefer to use them, you can use wire-end ferrules without an insulation collar (DIN 46228, form A, short design).

Required Tools

3.5 mm screwdriver or motorized screwdriver

Wiring Procedure



Warning

Injury to persons or damage to equipment if the power supply is not turned off.

If you wire the front connector of the FM 351 while it is live, you risk injury from electric shock.

Wire the FM 351 only when it is not live!

If no emergency stop switch is installed, damage can result from the connected units.

Install an emergency stop switch with which you can turn off the connected drives when you are controlling the FM 351 using the *Configuration Software*.

To wire up the front connector, follow the steps outlined below:

1. Strip 6 mm of insulation from the cords. If required, fit wire-end ferrules.
2. Open the front panel and position the front connector for wiring.
3. Thread the supplied strain relief into the front connector.
4. Fit the strain relief to the connector.
5. If you want to lead the cords out at the bottom, start at the bottom, otherwise at the top. Screw down unused terminals as well.
Use a torque of 0.6 to 0.8 Nm.
6. Pull the strain relief clamp for the cable row tight.
7. Put the front connector into the operating position (pressing the securing element).
8. You can complete the supplied label and insert it in the front panel.

Ground Connection

The ground of the encoder auxiliary supply is electrically connected to the ground of the CPU; in other words, terminal 2 (1M) must be connected with low resistance to the ground of the CPU.

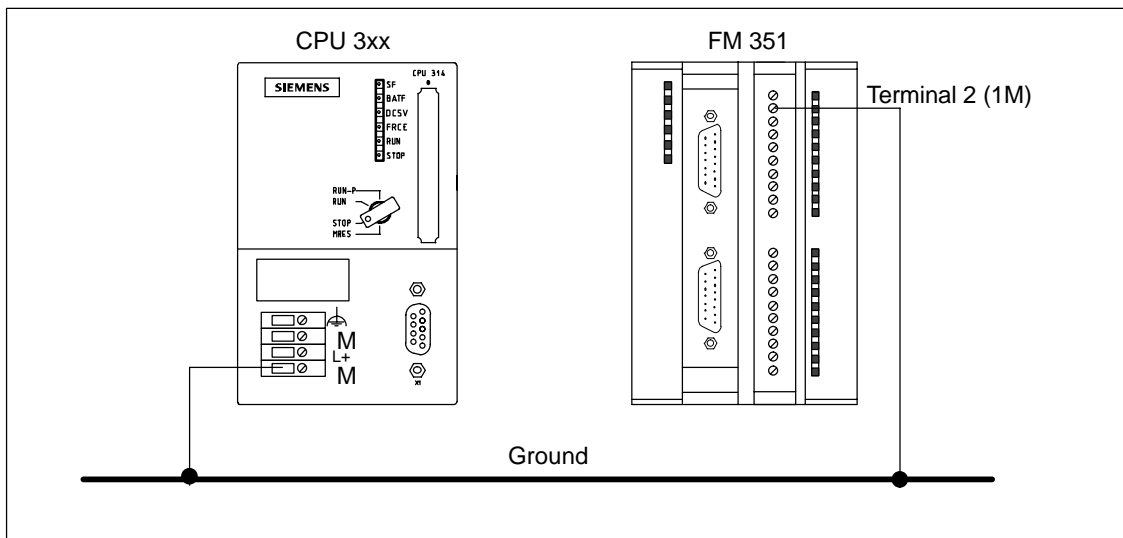

5

Installing the Configuration Package

Requirement

STEP 7, Version V4.02 or higher is correctly installed on your programming device/PC.

Content of the Configuration Package

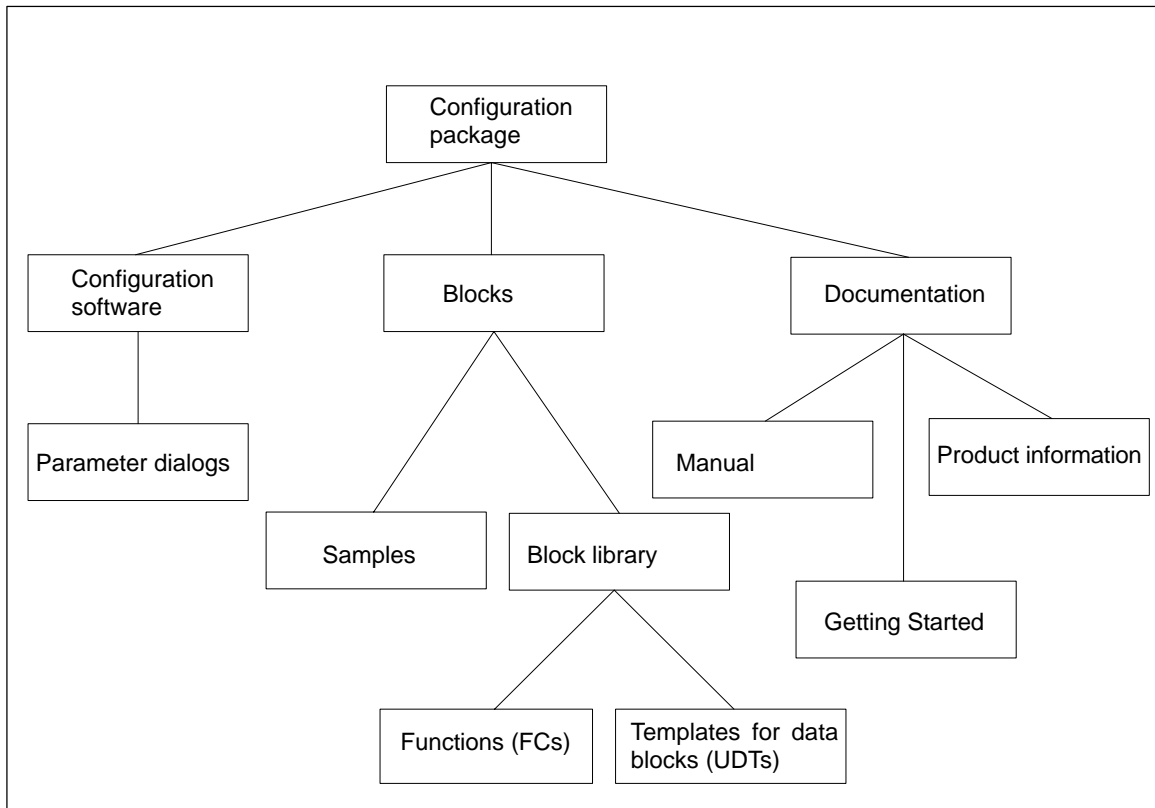

Figure 5-1 Content of the Configuration Package

Installation

The entire configuration package is located on the CD supplied. You install the configuration package as follows:

1. If you already have a configuration package on your system, uninstall it.
2. Insert the CD in the CD drive of your PC/programming device.
3. Start the software installation dialog in Windows 95/Windows NT/Windows 98 by clicking the "Add/Remove Programs" icon in the "Control Panel".
4. In this dialog, select the CD drive and the folder **FMx51\Disk1**, then select the file **Setup.exe** and start the installation.
5. Follow the instructions displayed by the installation program step by step.

Result: The components of the configuration package are installed in the following folders:

- **SIEMENS\STEP7\S7LIBS\FMx51LIB:** FCs, UDTs
- **SIEMENS\STEP7\S7FABS:** Configuration software, readme, online help
- **SIEMENS\STEP7\EXAMPLES:** Examples
- **SIEMENS\STEP7\S7MANUAL\S7FABS:** Getting Started, manuals

Note

If you installed STEP 7 in a folder other than SIEMENS\STEP7, this folder is entered.

Programming the FM 351

6

Chapter Overview

Section	Topic	Page
6.1	Basics of Programming an FM 351	6-2
6.2	FC ABS_INIT (FC0)	6-4
6.3	FC ABS_CTRL (FC1)	6-5
6.4	FC ABS_DIAG (FC2)	6-11
6.5	Data Blocks	6-13
6.6	Technical Data of the FCs and DBs for the FM 351	6-15
6.7	Fast Access to Module Data	6-17
6.8	Parameter Transfer Routes	6-19

6.1 Basics of Programming an FM 351

Task

You can assign parameters, control, and commission each channel of the FM 351 module per user program. The following chapters will help you to design a user program suitable for your application.

Preparations

- Open the block library FMx51LIB in the SIMATIC Manager and copy the required functions (FCs) and block templates (UDTs) to the block folder of your project. If the block numbers are already being used, assign new numbers. The block names are entered unchanged in the symbol table of your S7 program.

Name	Meaning
FC ABS_INIT (FC0)	This is required to initialize the channel DB following a module startup.
FC ABS_CTRL (FC1)	This is required for data exchange and for controlling the module.
FC ABS_DIAG (FC2)	This is required when you process detailed diagnostic information in the program or want to make this information available to an operator control and monitoring system.
UDT ABS_CHANTYPE (UDT 1)	This is required to generate a channel DB per channel; this is used by FC ABS_INIT and FC ABS_CTRL.
UDT ABS_DIAGTYPE (UDT 2)	This is required to create a diagnostic DB for each module; this is used by FC ABS_DIAG.
UDT ABS_PARATYPE (UDT 3)	This is required to create a parameter DB; this is used by FC ABS_CTRL to write or read machine data and incremental dimension tables.

- Create data blocks (DBs) using the UDTs in the block folder of your S7 program.
 - You require a separate channel DB for each channel.
 - If you want to write or read parameters using the user program, you require a separate parameter DB for each channel.
 - If you want your user program to run diagnostic functions, you require a diagnostic DB for each module.
- Enter the module address in the corresponding channel DB and, if required, also in the corresponding diagnostic DB at the address "MOD_ADDR". You can also have the address entered automatically by selecting the module in HW Config and then selecting a data block in the "Properties" dialog with the "Mod Addr" button.
- Enter the channel number and, if required, the number of the parameter DB in the relevant channel DB.

- If your programming device/PC is connected to a CPU, you can now download the FCs and DBs to the CPU.

The following schematic shows how the FM 351, FCs, DBs and OBs communicate.

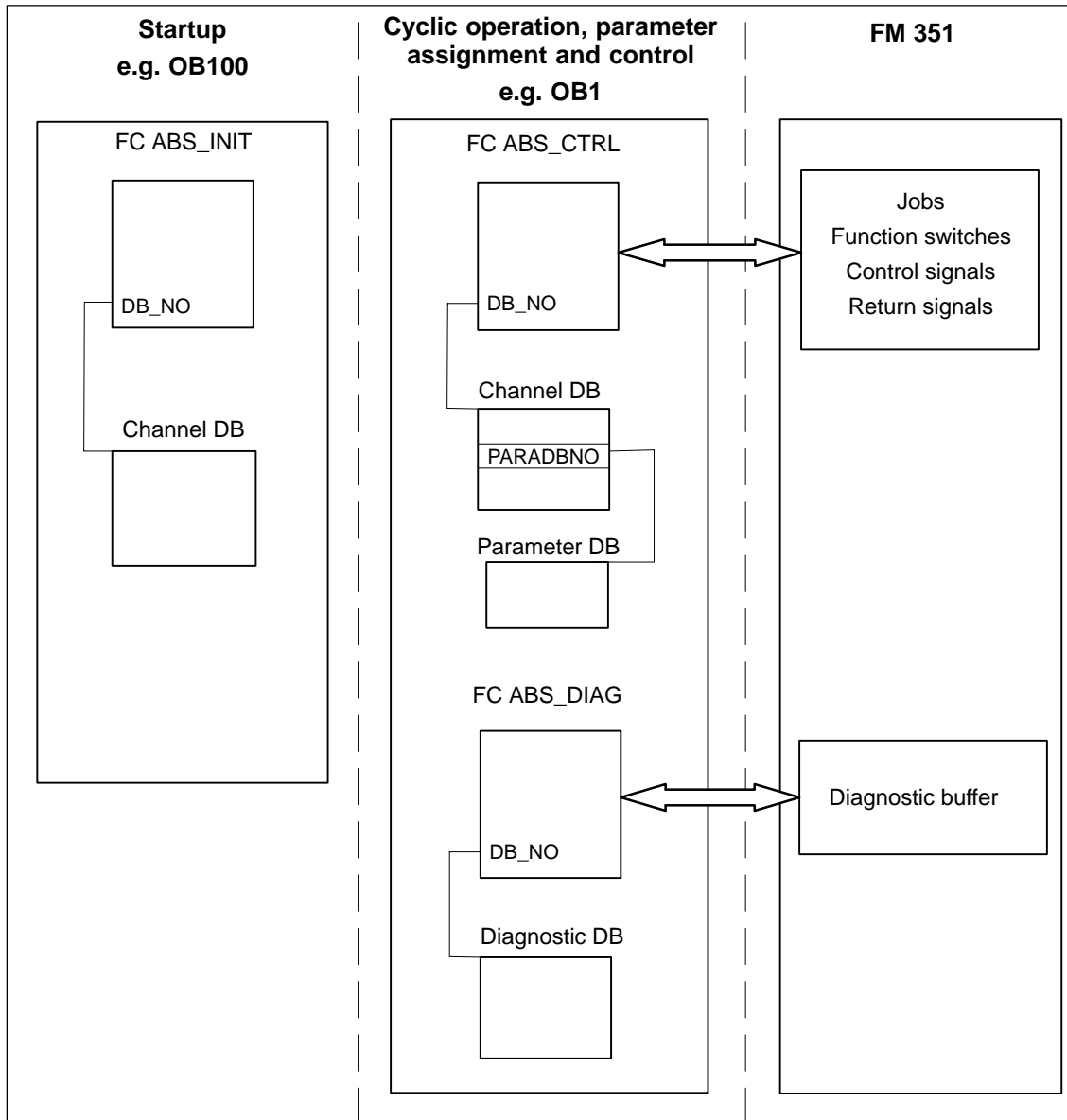

Figure 6-1 Data Exchange between FCs, DBs and the FM 351

6.2 FC ABS_INIT (FC0)

Task

FC ABS_INIT deletes the following data in the channel DB:

- The control signals
- The return signals
- The trigger, done, and error bits of the jobs
- The function switches and their done and error bits
- Job management for FC ABS_CTRL

Call

The function must be run through for each channel following a startup (power supply on) of the module or CPU. You should therefore call it, for example in the startup OB (OB100) and the remove/insert OB (OB83) or in the initialization phase of your user program. This ensures that your user program does not access old data following a CPU restart or a module startup.

Data Block Used

Channel DB:

The module address must be entered in the channel DB.

Call Parameters

Name	Data Type	P Type	Meaning
DB_NO	INT	IN	Channel DB number.

Return Values

This function does not return a value.

6.3 FC ABS_CTRL (FC1)

Tasks

Using FC ABS_CTRL, you can read the operating data of each channel of the module, assign parameters for the channels, and control the channel during operation using the control signals, return signals, function switches, and write/read jobs.

Each time it is called, the function performs the following activities:

- Read return signals:
FC ABS_CTRL reads all the return signals for a channel and enters them in the channel DB. Since the control signals and jobs are only executed following this, the return signals reflect the status of the channel before the block was called.
- Job management:
FC ABS_CTRL processes the write and read jobs and transfers data between the channel DB, parameter DB, and the module.
- Write control signals:
The control signals entered in the channel DB are transferred to the module.

Call

FC ABS_CTRL must be called cyclically (for example in OB1) for each channel.

Before you call FC ABS_CTRL, enter all the data in the channel DB that are required to execute the intended functions.

Data Blocks Used

- Channel DB:
The module address and the channel number must be entered in the channel DB. Incorrect information can lead to I/O access errors or to access to a different module causing incompatible data.
- Parameter DB:
If you want to write or read machine data using jobs, you require a parameter DB whose number must be entered in the channel DB.

Call Parameters

Name	Data Type	P Type	Meaning
DB_NO	INT	IN	Channel DB number.
RET_VAL	INT	OUT	Return value

Return Values

The function provides the following return values:

RET_VAL	BR	Description
1	1	At least one job active
0	1	No job active, no error
-1	0	Error: Data error (DATA_ERR) or communications error (JOB_ERR) occurred

Jobs

Data exchange with the module other than the control and return signals is handled using jobs.

To start a job, you set the corresponding trigger bit in the channel DB and provide the relevant data for write jobs. You then call FC ABS_CTRL to execute the job.

If you use the FM 351 centrally, a read job takes exactly one cycle. If you use the FM 351 decentrally, a read job may take several cycles.

Due to the required confirmations from the module, a write job requires at least three calls (or OB cycles).

Once a job has been executed completely, the block resets the trigger bit. The next time the block is called, the next job is located and executed.

For each job, there is a trigger bit (extension _EN for “enable”) and a done bit and error bit. These have the extensions _D (for “done”) or _ERR (for “error”) in the name. FC ABS_CTRL updates the done and error bits when the job has been executed. These bits should be set to 0 after they have been evaluated or before a new job is sent.

If you set the JOBRESET bit, all the done and error bits are reset before the pending jobs are processed. The JOBRESET bit is then set to 0 again.

Function Switches

The function switches activate and deactivate channel states. A job for writing the function switches is only executed when there is a change in a switch setting. The setting of the function switch is latched after the job has been executed.

Function switches and jobs can be used at the same time in one FC ABS_CTRL call.

As with the jobs, the function switches have trigger bits with the name extension _ON/_OFF, done bits with the extension _D and error bits with the extension _ERR.

To allow evaluation of the done and error bits of the function switches, you should set these bits to 0 before you send a job to modify a function switch.

Order of Job Execution

You can send several jobs at the same time. If no jobs are active, the job management of FC ABS_CTRL searches through the jobs starting at MDWR_EN to check whether trigger bits are set or whether modifications have been made to function switches. When a job is found, it is executed. Once the job is completed, the job management searches for the next job to be executed. Once the search has reached the last job (ENCVAL_EN), the search starts again at the MDWR_EN job. This search is repeated until all jobs have been executed.

The jobs are executed in the following order which has proved practical from a technological point of view:

Order	Addr. in Channel DB			Reset by
Write jobs				
1	35.0	MDWR_EN	Write machine data	FC1
2	35.1	MD_EN	Activate machine data	FC1
	35.2	DELDIST_EN	Delete remaining distance	
	35.3	AVALREM_EN	Cancel set actual value	
	36.4	DELDIAG_EN	Delete diagnostic buffer	
3	35.4	TRGL1WR_EN	Write incr. dim. table 1	FC1
4	35.5	TRGL2WR_EN	Write incr. dim. table 2	FC1
5	35.6	REFPT_EN	Set reference point	FC1
6	34.0 34.1 34.2	Function switches		User program
		PLOOP_ON	Loop traverse in plus direction	
		MLOOP_ON	Loop traverse in minus direction	
	34.2	EI_OFF	Do not evaluate enable input	
7	35.7	AVAL_EN	Set actual value.	FC1
10	36.2	TRG252_254_EN	Write incr. dim. for incr. dim. no. 254	FC1
11	36.3	TRG255_EN	Write incr. dim. for incr. dim. no. 255	FC1
Read jobs				
12	36.5	MDRD_EN	Read machine data	FC1
13	36.6	TRGL1RD_EN	Read incr. dim. table 1	FC1
14	36.7	TRGL2RD_EN	Read incr. dim. table 2	FC1
16	37.1	ACTSPD_EN	Read actual speed, distance remaining and current incr. dim.	FC1
17	37.2	ENCVAL_EN	Read Encoder Data	FC1

This order allows you to start a complete positioning operation with a set of jobs and control signals. The jobs range from writing and activating the machine data, setting the external enable input to writing the incremental dimensions for incremental approaches.

Control Signals

If there is a STOP signal or operator error or if the drive enable is not set, the block resets the control signals START, DIR_M and DIR_P.

You can start a positioning operation again after acknowledging the operator error (OT_ERR_A=1). With this acknowledgment, it is not possible to send further jobs and control signals.

The block sets the acknowledgment of an operator error (OT_ERR_A) to 0 when no operator error has been detected.

The block resets the start signals START, DIR_P and DIR_M when the channel signals that a positioning operation has started (except in the "Jogging" mode).

The block holds back all control signals with the exception of the operator error acknowledgment OT_ERR_A if the axis has not had parameters assigned.

Jobs and Control Signals

You can send several jobs at the same time even along with the control signals necessary for the positioning operation. If at least one write job is sent at the same time as the control signals START, DIR_M or DIR_P, the block holds back the control signals until the write jobs have been executed.

Jobs During an Active Positioning Operation

If the write jobs listed in the table below are sent during a positioning operation, they are held back until the end of the operation and are only executed the next time the block is called.

Address	Name	Type	Initial Value	Comment
34.0	PLOOP_ON	BOOL	FALSE	1 = loop traverse in plus direction
34.1	MLOOP_ON	BOOL	FALSE	1 = loop traverse in minus direction
34.2	EI_OFF	BOOL	FALSE	1 = do not evaluate enable input
35.1	MD_EN	BOOL	FALSE	1 = activate machine data
35.2	DELDIST_EN	BOOL	FALSE	1 = delete remaining distance
35.3	AVALREM_EN	BOOL	FALSE	1 = cancel set actual value
35.6	REFPT_EN	BOOL	FALSE	1 = Set reference point coordinate
35.7	AVAL_EN	BOOL	FALSE	1 = set actual value.
36.4	DELDIAG_EN	BOOL	FALSE	1 = delete diagnostic buffer

Startup

When the module or CPU starts up, call FC ABS_INIT (see Section 6.2, page 6-4). Among other things, the function switches are reset. FC ABS_CTRL acknowledges the module startup. During this time, RET_VAL and JOBBUSY are set to 1.

Job Status

You can check the status of job execution using the return value RET_VAL and the JOBBUSY activity bit in the channel DB. You can evaluate the status of a single job based on the trigger, done, and error bits of the job.

	RET_VAL	JOBBUSY	Trigger bit _EN	Done bit _D	Error bit _ERR
Job active	1	1	1	0	0
Job completed without error	0	0	0	1	0
Job completed with error	-1	0	0	1	1
Write job aborted	-1	0	0	0	1

Response to Errors

If incorrect data were written during a write job, the channel returns the message DATA_ERR = 1 in the channel DB. If an error occurs in communication with the module during a write or read job, the cause of the error is entered in the JOB_ERR parameter in the channel DB.

- Error in a write job:

If an error occurs in a job, the trigger bit is reset and the error bit (_ERR) and the done bit (_D) are set. The trigger bit is also reset but only the error bit (_ERR) is set for all write jobs still pending. Any pending write jobs are canceled, since one job may depend on another.

The pending read jobs continue to be processed. JOB_ERR is set again for each job.

- Error in a read job:

If an error occurs in a job, the trigger bit is reset and the error bit (_ERR) and the done bit (_D) are set.

The read jobs still pending continue to be processed. JOB_ERR is set again for each job.

For more detailed information on errors, refer to the description of the parameters JOB_ERR and DATA_ERR (see Section 11 and Appendix C.3, page C-11).

Program Structure

Figure 6-2 shows the structure of a user program for controlling a channel of the module cyclically after a single startup initialization. The return value (RET_VAL) of FC ABS_CTRL is used in the user program for general error evaluation.

An independent and simultaneous startup is possible for each further channel as shown in Figure 6-2.

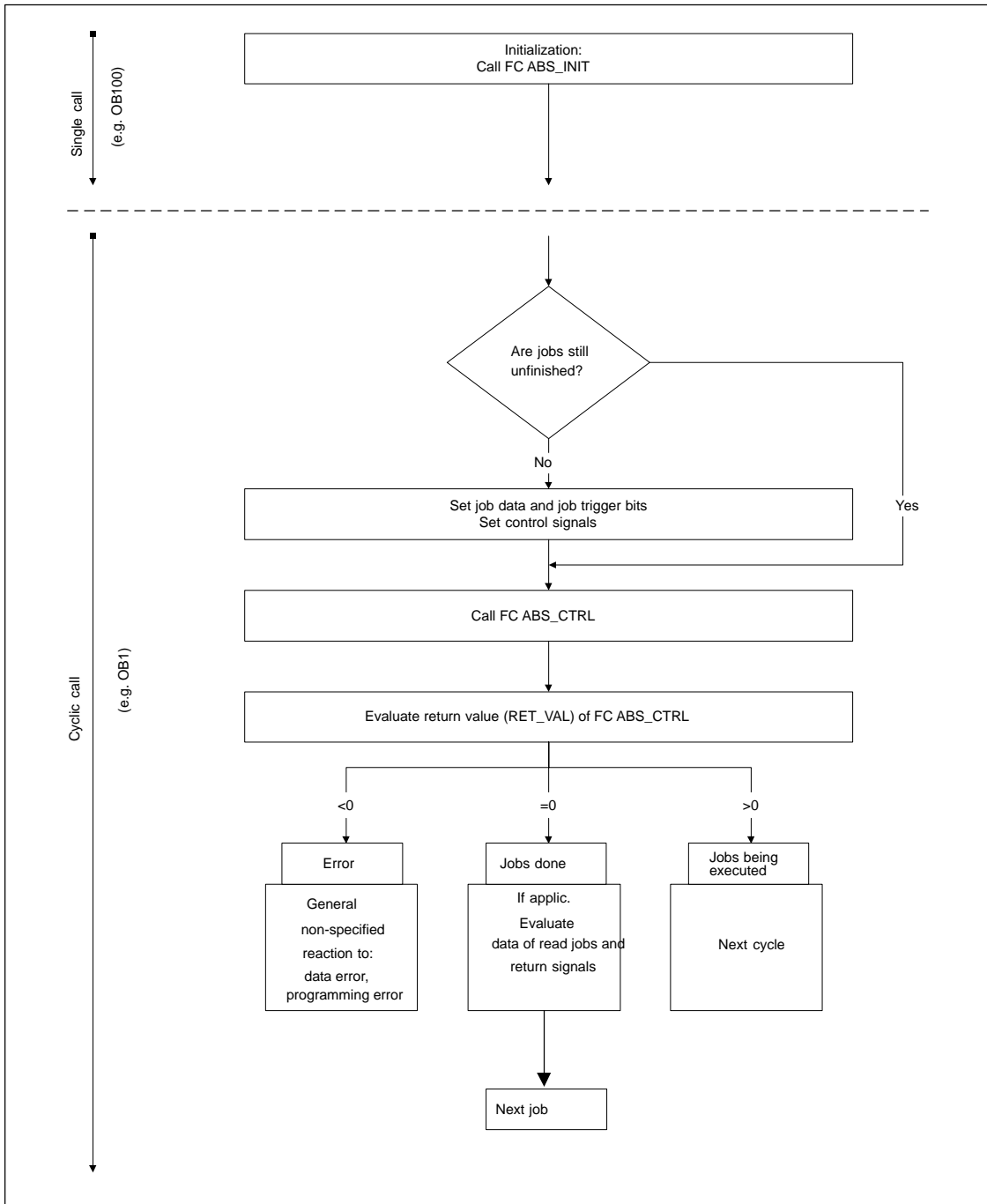

Figure 6-2 General Program Structure

6.4 FC ABS_DIAG (FC2)

Tasks

Using FC ABS_DIAG, you read out the diagnostic buffer of the module and can make it available for display in an operator control and monitoring system or for programmed evaluation.

Call

The function must be called cyclically (for example OB 1). An additional call in an interrupt OB is not permitted. For complete execution of this function, at least two calls (cycles) are required.

The function reads out the diagnostic buffer when a new entry is indicated in the diagnostic buffer by the return signal DIAG = 1 in the channel DB. After the diagnostic buffer has been read, the DIAG bit in the channel DB is set to 0 by the module.

Data Block Used

Diagnostic DB:

The module address must be entered in the diagnostic DB. The latest entry in the diagnostic buffer is entered in the DIAG[1] structure and the oldest entry in the DIAG[9] structure.

Call Parameters

Name	Data Type	P Type	Meaning
DB_NO	INT	IN	Number of the diagnostic DB
RET_VAL	INT	OUT	Return value

Return Values

The function provides the following return values:

RET_VAL	BR	Description
1	1	job active
0	1	No job active, no error
-1	0	Error

Jobs

You can read the diagnostic buffer whether or not there is a new entry by setting the DIAGRD_EN trigger bit in the diagnostic DB. After reading the diagnostic buffer, the trigger bit is set to 0.

Execute this job following a CPU startup and a module startup. This ensures that the content of the diagnostic DB matches the content of the diagnostic buffer of the module even if the module has made no new entry in the diagnostic buffer.

Startup

There is no startup processing associated with the function.

Response to Errors

If an error occurs in the execution of the job, the cause of the error can be found in the diagnostic DB in the JOB_ERR parameter (see Chapter 11 and Appendix C.3, page C-11).

6.5 Data Blocks

6.5.1 Templates for Data Blocks

The supplied library (FMx51LIB) contains a block template (UDT) for each data block. Based on these UDTs, you can create data blocks with any number and name you wish.

6.5.2 Channel DB

Task

The channel DB (see Appendix C.1, page C-2) is the data interface between the user program and the FM 351. It contains and receives all the data required for controlling and operating a channel.

Structure

The channel DB is subdivided into various areas:

Channel DB
Module address *)
Channel number
Number of the parameter DB
Control signals
return signals
Function switches
Trigger bits for write jobs
Trigger bits for read jobs
Done bits
Error bits
Job management for functions
Data for jobs

*) You can enter the address with the configuration software

6.5.3 Diagnostic DB

Task

The diagnostic DB (see Appendix C.3, page C-11) contains the data for FC ABS_DIAG and also contains the diagnostic buffer of the module created by this function.

Structure

Diagnostic DB
Module address
Internal data
Job status
Trigger bit
Diagnostic buffer

6.5.4 Parameter DB

Task

If you want to modify the machine data and incremental dimension tables during operation, you require a parameter DB (see Appendix C.2, page C-9) in which these data are stored. The parameters can be modified by the user program or by an operator control and monitoring system.

You can export the data displayed in the configuration software to a parameter DB. You can also import a parameter DB into the configuration software and display it there.

There can be several sets of parameter data for each channel (for example for different recipes) the required set being selected in the program.

Structure

Parameter DB
Machine data
Incremental dimension tables

6.6 Technical Specifications of the FCs and DBs for the FM 351

The table below provides you with an overview of the technical data of the functions and data blocks.

Table 6-1 Technical Specifications of the Functions and Data Blocks for the FM 351

No.	Block Name	Version	Space in Load Memory (bytes)	Space in Main Memory (bytes)	Space in Local Data Area (bytes)	MC7 Code/Data (bytes)	Called System Functions
FC0	FC ABS_INIT	1.0	184	130	2	94	
FC1	FC ABS_CTRL	1.0	4548	4176	34	4140	SFC58: WR_REC, SFC59: RD_REC
FC2	FC ABS_DIAG	1.0	1800	1658	42	1622	SFC59: RD_REC
	Channel DB	–	638	184	–	148	
	Parameter DB	–	840	556	–	520	
	Diagnostic DB	–	524	388	–	352	

Module Cycle

The return signals of a channel are updated by the module every 8 ms.

Execution Times

The following table provides you with an overview of the execution times of the functions for the FM 351. The run time from the first function call to the done message (trigger bit reset) is shown. The cycle is extended by between 1 and 2 ms when a function is called.

Table 6-2 Execution Times of the Functions for the FM 351

Block	Block Name/Job	CPU 315-2 DP (6ES7 315-2AF03-0AB0)
		Run time in ms
FC0	FC ABS_INIT	0.14
FC1	FC ABS_CTRL	
	Control/return	0.66
	MDWR_EN	95.6
	MD_EN	10.2
	TRGL1WR_EN	68.1
	DELDIST_EN	12.3
	REFPT_EN	15.4
	Function switches	12.3
	AVAL_EN	15.4
	TRG252_254_EN	15.4
	TRG255_EN	18.0
	DELDIAG_EN	12.3
	MDRD_EN	14.7
	TRGL1RD_EN	22.1
ACTPOS_EN	6.4	
ENCVAL_EN	6.4	
FC2	FC ABS_DIAG	
	Idle run	0.3
	Read diagnostic buffer	30.8

6.7 Fast Access to Module Data

Application

In special applications or in an interrupt level, particularly fast access to return and control signals may be necessary. You can obtain this data directly via the input and output areas of the module.

To coordinate startup following each module startup (for example after inserting the module, CPU STOP → RUN), FC ABS_CTRL must be called continuously until the end of the startup is indicated by RET_VAL = 0. Following this, you must no longer use FC ABS_CTRL.

Note

It is not possible to use FC ABS_CTRL in conjunction with write access.

Direct Access for Reading Return Signals

The byte addresses are specified relative to the base address of the outputs of the particular channel. The names of the parameters are those in the channel DB (see Appendix C.1, page C-2).

Base address of channel 1 = base address of module

Base address of channel 2 = base address of module + 8

In STL, you access the data with the commands PIB (read 1 byte), PIW (read 2 bytes) and PID (read 4 bytes).

Addresses	Bit number							
	7	6	5	4	3	2	1	0
Byte 0	PARA	internal	internal	DATA_ERR	OT_ERR	DIAG	internal	internal
Byte 1	CHGOVER	CUTOFF	ZSPEED	SPEED_OUT	0	WAIT_EI	WORKING	ST_EN BLD
Byte 2	MODE_OUT							
Byte 3	POS_RCD	0	0	0	GO_P	GO_M	0	SYNC
Byte 4	ACT_POS							
Byte 5								
Byte 6								
Byte 7								

Example: Actual position (ACT_POS)

STL	Explanation
Example	The base address of the module is 512
L PID 516	Read actual position value (ACT_POS) of channel 1 using direct access: Base address of the channel + 4

Direct Access for Writing Control Signals

The byte addresses are specified relative to the base address of the inputs of the particular channel. The names of the parameters are those in the channel DB (see Appendix C.1, page C-2).

Base address of channel 1 = base address of module

Base address of channel 2 = base address of module + 8

In STL, you access the data with the commands PQB (write 1 byte), PQW (write 2 bytes) and PQD (write 4 bytes).

Address	Bit number							
	7	6	5	4	3	2	1	0
Byte 0	0	0	0	0	OT_ERR_A	0	0	0
Byte 1	DRV_EN	0	0	0	DIR_P	DIR_M	STOP	START
Byte 2	MODE_IN							
Byte 3	MODE_TYPE							
Byte 4	Reserved							
Byte 5	Reserved							
Byte 6	Reserved							
Byte 7	Reserved							

Example: START signals channel 2

STL	Explanation
Example	The base address of the module is 512
L 2#10001000	Set DRV_EN and DIR_P to 1
T PQB 521	Write signals for channel 2 using direct access: Base address of the module + 8 + 1

6.8 Parameter Transfer Routes

The term parameter includes the following machine data and incremental dimensions.

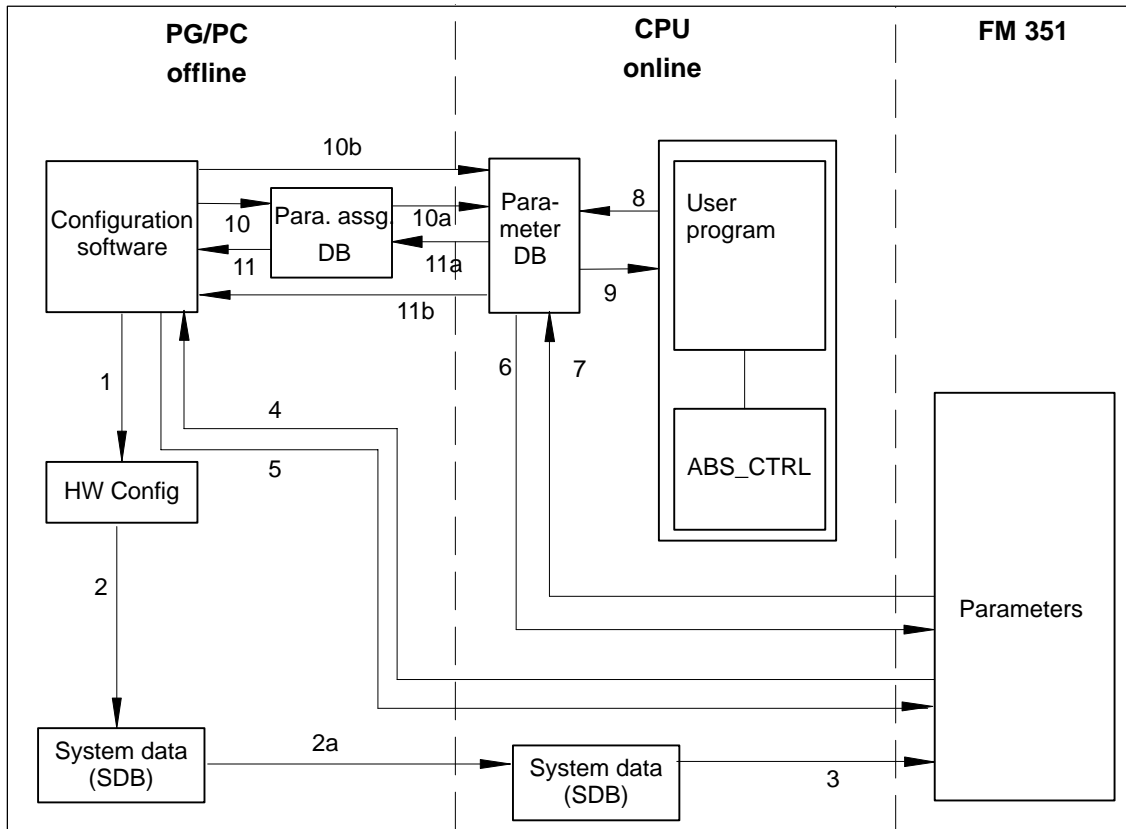

Figure 6-3 Parameter Transfer Routes

1	Save parameters in the configuration software.
2	Save and compile the hardware configuration.
2a	Download the hardware configuration to the CPU. The CPU executes Step 3 automatically.
3	The CPU writes the parameters to the module during system parameter assignment.
4	Upload parameters of a module channel to the PG with "PLC – Upload Channel".
5	Download parameters from the PG to a module channel with "PLC – Download Channel".
6	Write parameters to a channel of the module using jobs in the user program.
7	Read parameters from a channel of the module using jobs in the user program.
8	Store parameters from the user program in the online DB.
9	Read parameters into the user program from the online DB.
10	Export parameters from the configuration software to the offline DB.
10a	Download the offline DB to the CPU.
10b	Export parameters from the configuration software to the online DB.
11	Import parameters from the offline DB to the configuration software.
11a	Upload parameters from the online DB to the programming device.
11b	Import parameters from the online DB to the configuration software.

Typical Situations for the Transfer of Parameters:

- You edit the parameters with the configuration software. You then want the channels of the module to have parameters assigned automatically during startup.
Action required: steps 1, 2 and 2a.
- You modify the parameters during commissioning in the test mode in the configuration software: Action required: steps 4 and 5.
- You want the parameters modified during commissioning to be loaded automatically during startup:
Action required: steps 1, 2 and 2a.
- You create the parameters with the configuration software. You want the channels of the module to be assigned parameters during startup only by the user program using data blocks:
Action required: steps 10, 10a and 6 or 10b and 6.
- You want to create data for recipes::
Action required: steps 10 and 10a.
- You create the parameters with the configuration software. These should be available to the user program for temporary modifications.
Action required: steps 1, 2 and 2a for automatic parameter assignment.
Action required: steps 10, 10a, 9, 8 and 6 for access by the user program.
- You modify existing parameters (exclusively) with the user program:
Action required: steps 7, 9, 8 and 6.
- You want to view the data modified by the user program in the configuration software:
Action required: steps 11a and 11 or only 11b.
- The parameters modified by the user program should be downloaded automatically during startup:
Action required: steps 11b or 11a, 11 and then 1, 2, 2a.

Putting the FM 351 into Operation

7

Important Note

Please read the points in the following warning carefully.



Warning

Injury to persons and damage to equipment can occur.

To prevent personal injury and material damage, please note the following points:

- Install an EMERGENCY STOP switch in the vicinity of the computer. This is the only means of ensuring that the system can be switched off safely in the event of a computer or software failure.
 - Install a hardware limit switch directly connected to the power units of all drives.
 - Make sure that nobody can obtain access to the area of the system that contains moving parts.
 - Controlling and monitoring the FM 351 from within your program and from the "Test > Commission" dialog at the same time can lead to conflicts with unforeseeable effects. For this reason, always switch the CPU to STOP when you work in the Test dialog or deactivate your program.
-

Hardware Installation and Wiring

In this first section you install the FM 351 in your S7-300 and wire the external peripheral components.

Step	What needs to be done?	✓
1	Install the FM 351 (see Chapter 3) Insert the module in one of the slots 4 to 11.	<input type="checkbox"/>
2	Wire the FM 351 (see chapter 4) <ul style="list-style-type: none"> • Wire the front connector of the FM 351: <ul style="list-style-type: none"> – Auxiliary power supply for the encoders – Auxiliary power supply for the load current – Digital inputs – Digital outputs • Connect the encoders 	<input type="checkbox"/> <input type="checkbox"/> <input type="checkbox"/> <input type="checkbox"/> <input type="checkbox"/>
3	Check the switches relevant for safety Check that the following switches are functioning correctly: <ul style="list-style-type: none"> • The emergency stop switch • The hardware limit switch 	<input type="checkbox"/> <input type="checkbox"/>
4	Front connector The front connector must sit firmly.	<input type="checkbox"/>
5	Check the shielding of each individual cable.	<input type="checkbox"/>
6	Switch on the power supply Switch the CPU to the STOP state (safe state). Turn off the 24 V power supply for the auxiliary voltages.	<input type="checkbox"/> <input type="checkbox"/>

Creating a Project

Create a project in *STEP 7*.

The steps required to set up a project in the SIMATIC Manager are described below (without using a wizard).

Step	What needs to be done?	✓
1	If you have not already done so, install the configuration package.	<input type="checkbox"/>
2	Create a new project in the SIMATIC manager (File > New).	<input type="checkbox"/>
3	Insert a station in your project (Insert > Station).	<input type="checkbox"/>
4	Select the station and start the configuration user interface "HW Config" by double-clicking "Hardware".	<input type="checkbox"/>
5	Insert a rack in your hardware configuration with the following: <ul style="list-style-type: none"> • A power supply (PS) • CPU • Function module (FM 351) 	<input type="checkbox"/>
6	Save this hardware configuration in HW Config (Station > Save).	<input type="checkbox"/>

Preparations for Programming

Create the blocks you require in your project if you want to access the module from the user program.

Step	What needs to be done?	✓
1	Select the library FMX51LIB in the SIMATIC Manager (File > Open > Libraries).	<input type="checkbox"/>
2	From the library, copy the functions FC0, FC1, and the channel DB template UDT 1 to the blocks folder.	<input type="checkbox"/>
3	Create a channel DB for each channel based on the UDT 1 template and enter the channel number.	<input type="checkbox"/>
4	If you want to program diagnostic evaluation, copy FC 2 and UDT 2 and create a diagnostic DB for each module.	<input type="checkbox"/>
5	If you want to write or read machine data and incremental dimension tables in the user program, you require UDT 3 to create a parameter DB for each channel.	<input type="checkbox"/>

Parameter Assignment using the Configuration Software

When you first put the module into operation, assign the parameters to it using the parameter assignment dialogs of the configuration software.

Step	What needs to be done?	✓
1	Select the tier in the rack containing the FM 351 module.	<input type="checkbox"/>
2	Now double-click to start the parameter assignment dialogs for the FM 351.	<input type="checkbox"/>
3	Using the menu command File > Properties , you can modify the following settings: <ul style="list-style-type: none"> • General You can modify the name and enter a comment. • Addresses If you change the base address, you must also modify the end address. Note down the module address displayed. The module address must be entered in the MOD_ADDR parameter in the channel DB and, if required, also in the diagnostic DB. You can have the address entered automatically by clicking the MOD_Adr button and then select the channel DB and, if required, the diagnostic DB. • Basic Parameters You can set the type of interrupt. 	<input type="checkbox"/>
4	Set the appropriate parameters in the dialogs Drive , Axis , Encoder and Incremental Dimensions .	<input type="checkbox"/>
5	With Edit > Create Channel , you can create your channels.	<input type="checkbox"/>
6	Save the parameter settings with the menu command File > Save .	<input type="checkbox"/>
7	Close the parameter dialogs with File > Exit .	<input type="checkbox"/>
8	Save the hardware configuration in HW Config with Station > Save and Compile .	<input type="checkbox"/>
9	Set up an online connection to the CPU and download the hardware configuration to the CPU. The parameter data are transferred to the FM 351.	<input type="checkbox"/>

Test and Commissioning

You can test the entries and modifications you have made in the parameter dialogs of the configuration software.

Step	What needs to be done?	✓
1	Check your data with the dialogs Test > Commission , Test > Service and Test > Error Evaluation .	<input type="checkbox"/>
2	You can modify incorrect machine data in the Test > Commission dialog. These modifications are valid until the CPU next changes from STOP to RUN.	<input type="checkbox"/>
3	You can save the corrected machine data on the CPU by repeating steps 6 to 9 of the previous table.	<input type="checkbox"/>

Testing Modes, Jobs, and Function Switches

Using the following tests you can check the correct assignment of parameters for the FM 351.

Step	What needs to be done?	✓
1	Synchronize the axis	
	<ul style="list-style-type: none"> • Incremental Encoders <ul style="list-style-type: none"> – Select “set reference point”. Enter the corresponding value (see Section 9.6, page 9-25). or – Select the “Reference Point Approach” mode (see Section 9.3, page 9-11). 	<ul style="list-style-type: none"> • Absolute Encoders <ul style="list-style-type: none"> – The FM 351 is synchronized immediately after parameter assignment. – Make an absolute encoder adjustment (see Section 8.6, page 8-19).
	Check the actual status of the axis. The actual position must agree with the position indicated.	<input type="checkbox"/>
2	Select the Jog operating mode.	<input type="checkbox"/>
	<ul style="list-style-type: none"> • Check the correct interconnection of the outputs (control type) and the actual value. <ul style="list-style-type: none"> – Move the axis in the plus and minus directions at creep speed. – Move the axis in the plus and minus direction at rapid speed. • Check the encoder resolution (see Section 8.7, page 8-22) <ul style="list-style-type: none"> – Move the drive over a defined distance in a defined direction. The actual distance traveled must match the display in the Test > Commissioning dialog. 	<input type="checkbox"/>
3	Select the operating mode incremental mode	
	<ul style="list-style-type: none"> • absolute with incremental dimension number 255 <ul style="list-style-type: none"> – Check the travel with the defined incremental dimension – and adapt the switchover and switch-off differences to your system based on incremental dimension 255. 	<input type="checkbox"/>
4	Test the other function switches and jobs according to your applications	<input type="checkbox"/>
	<ul style="list-style-type: none"> • For example loop traverse, set actual value 	<input type="checkbox"/>

Note

If you use the FM 351 via PROFIBUS-DP; the CPU must be set to RUN or RUN-P during testing and commissioning. Otherwise, you cannot control the FM 351.

Note

If you set the drive enable in the commissioning dialog with the CPU in the STOP mode and then exit all the parameter dialogs, the drive enable is canceled.

Preparing the Channel DB

Step	What needs to be done?	✓
1	Open the channel DB.	<input type="checkbox"/>
2	Check the following entries: <ul style="list-style-type: none"> • The module address in the MOD_ADDR parameter • The channel number in the CH_NO parameter • If applicable, the number of the parameter DB in the PARADBNO parameter 	<input type="checkbox"/> <input type="checkbox"/> <input type="checkbox"/>
3	Save the channel DB (File > Save).	<input type="checkbox"/>

Preparing the Diagnostic DB

Step	What needs to be done?	✓
1	Open the diagnostic DB	<input type="checkbox"/>
2	Check whether the module address has already been entered in the MOD_ADDR parameter.	<input type="checkbox"/>
3	Save the diagnostic DB (File > Save).	<input type="checkbox"/>

Linking the Functions

Step	What needs to be done?	✓
1	Link the required functions in your user program.	<input type="checkbox"/>

Downloading Blocks to the CPU

Step	What needs to be done?	✓
1	Select the blocks in the SIMATIC manager and download them with the menu command PLC > Download to CPU .	<input type="checkbox"/>

Machine Data and Incremental Dimensions

8

Chapter Overview

Section	Topic	Page
8.1	Writing and Reading Machine Data and Incremental Dimension Tables	8-2
8.2	System of Units	8-5
8.3	Machine Data for the Drive	8-6
8.4	Machine Data for the Axis	8-12
8.5	Machine Data for the Encoder	8-15
8.6	Absolute Encoder Adjustment	8-19
8.7	Resolution	8-22
8.8	Increments	8-24

8.1 Writing and Reading Machine Data and Incremental Dimension Tables

This chapter describes how to modify and read out parameters during operation using your application.

All the parameters are stored in the parameter DB.

- The machine data are in the parameter DB at addresses 4.0 to 116.0.
- Incremental dimension tables are located in the parameter DB from addresses 120.0 to 516.0.

You must enter the number of the parameter DB in the appropriate channel DB.

You can enter the parameters either with the DB editor or more conveniently in the dialogs “Drive”, “Axis”, “Encoder” and “Incremental Dimensions” and write them to the parameter DB using the “Export” function.

You can import the parameters from an existing parameter DB into the dialogs with the “Import” function.

Writing, Activating and Reading Machine Data

With the machine data, you adapt the FM 351 to the axis and the encoder.

Initial parameter assignment

If the channel does not yet have machine data, follow the steps outlined below when assigning parameters for the first time without using the parameter dialogs:

- Enter the new values in the parameter DB and save it.
- Download the parameter DB to the CPU.
- Set the following trigger bit in the channel DB for the job:
 - Write machine data (MDWR_EN).
- Call the FC ABS_CTRL function in the cyclic user program.

Modifying machine data

To modify machine data using your application, follow the steps outlined below:

- Enter the new values in the parameter DB.
- Set the trigger bits in the channel DB for the following jobs:
 - Write machine data (MDWR_EN)
 - Activate machine data (MD_EN)
- Call the FC ABS_CTRL function in the cyclic user program.

If you set the trigger bits for these jobs all at once, FC ABS_CTRL makes sure that the jobs are processed in the correct order.

Otherwise, always modify the machine data in the following order:

- write machine data
- activate machine data

Reading machine data

To read the current machine data from a channel, follow the steps outlined below:

- Set the following trigger bit in the channel DB:
 - Read machine data (MDRD_EN)
- Call the FC ABS_CTRL function in the cyclic user program.

This enters the current machine data in the parameter DB on the CPU.

Excerpt from the Channel DB

Address	Name	Data Type	Initial Value	Description
35.0	MDWR_EN	BOOL	FALSE	1 = write machine data
35.1	MD_EN	BOOL	FALSE	1 = activate machine data
36.5	MDRD_EN	BOOL	FALSE	1 = read machine data

Writing and Reading Incremental Dimension Tables**Initial parameter assignment**

If the channel does not yet have incremental dimension tables, follow the steps below when making the initial parameter assignment without the configuration software:

- Enter the new values in the parameter DB and save it.
- Download the parameter DB to the CPU.
- Set the trigger bits in the channel DB for the following jobs:
 - Write incremental dimension table 1 (TRGL1WR_EN) and / or write incremental dimension table 2 (TRGL2WR_EN)
- Call the FC ABS_CTRL function in the cyclic user program.

Modifying incremental dimension tables

To modify incremental dimension tables using your application, follow the steps outlined below:

- Enter the new values in the parameter DB.
- Set the trigger bits in the channel DB for the following jobs:
 - Write incremental dimension table 1 (TRGL1WR_EN) and / or write incremental dimension table 2 (TRGL2WR_EN)
- Call the FC ABS_CTRL function in the cyclic user program.

Reading incremental dimension tables

To read the incremental dimension tables from a channel, follow the steps outlined below:

- Set the trigger bits in the channel DB for the following jobs:
 - Read incremental dimension table 1 (TRGL1RD_EN) and / or read incremental dimension table 2 (TRGL2RD_EN)
- Call the FC ABS_CTRL function in the cyclic user program.

The incremental dimension tables are stored in the parameter DB on the CPU.

Excerpt from the Channel DB

Address	Name	Data Type	Initial Value	Description
35.4	TRGL1WR_EN	BOOL	FALSE	1 = write incr. dim. table 1 (1 ... 50)
35.5	TRGL2WR_EN	BOOL	FALSE	1 = write incr. dim. table 2 (51 ... 100)
36.6	TRGL1RD_EN	BOOL	FALSE	1 = read incr. dim. table 1 (1 ... 50)
36.7	TRGL2RD_EN	BOOL	FALSE	1 = read incr. dim. table 2 (51 ... 100)

Note

If parameters are modified that are relevant for the synchronization, the following actions are taken by the module for the relevant channel when the machine data are activated:

- Synchronization deleted
- The function switches and zero point offset are reset
- All previous machine data and incremental dimension tables become invalid

The following parameters are relevant for synchronization:

- Axis type
 - End of rotary axis
 - Encoder type
 - Displacement per encoder rev.
 - Increments per encoder rev.
 - Number of revolutions.
 - Reference-point coordinate
 - Absolute encoder adjustment
 - Type of reference point approach
 - Count direction
-

8.2 System of Units

Selecting a Unit

In the configuration software of the FM 351, you can select one of the following systems of units for entering and outputting data:

- mm (default)
- inches
- degrees

Note

If you change the unit in the parameter dialogs, the values are calculated in the new system. This can lead to rounding errors.

If you change the system of units by programming with the jobs “write machine data” and “activate machine data”, the values are **not** automatically recalculated.

System of Units in the Parameter DB

Address	Name	Data Type	Initial Value	Description
8.0	UNITS	DINT	L#1	Units 1 = 10^{-3} mm 2 = 10^{-4} inches 3 = 10^{-4} degrees 4 = 10^{-2} degrees 6 = 10^{-3} degrees

Standard System of Units

In this manual, the **limit values** are always specified in the **system of units mm**. To define the limits in other systems of units, please make the following conversion:

To convert....	Calculate
mm → inches	Limit value (inches) = limit value (mm) · 0.1
mm → deg	Limit value (degrees) = limit value (mm) · 0.1
10^{-4} (4 decimal places)	Limit value (degrees) = limit value (mm) · 1
10^{-3} (3 decimal places)	Limit value (degrees) = limit value (mm) · 10
10^{-2} (2 decimal places)	

Relationship between Increments and System of Units

The encoder signals of a connected encoder are evaluated by the FM 351 and converted to the current system of units. For the conversion, the resolution is used (see Section 8.7, page 8-22).

If the FM 351

- has counted 10 increments and
 - a resolution of 100 μm per increment is set by the encoder parameters,
- this means that the axis was moved by a distance of 1 mm.

8.3 Machine Data for the Drive

Drive Data

Address	Name	Data Type	Initial Value	Description
92.0	CTRL_TYPE	DINT	L#1	Control Mode: The control mode describes how the four digital outputs per channel operate a connected motor via the power controller. x stands for channel 1 and 2
Control mode 1				
	V_{rapid}			
	V_{creep}			
Rapid speed	xQ0			
Creep speed	xQ1			
Travel plus	xQ2			
Travel minus	xQ3			
Control mode 2				
	V_{rapid}			
	V_{creep}			
Rapid/creep speed	xQ0			
Position reached	xQ1			
Travel plus	xQ2			
Travel minus	xQ3			

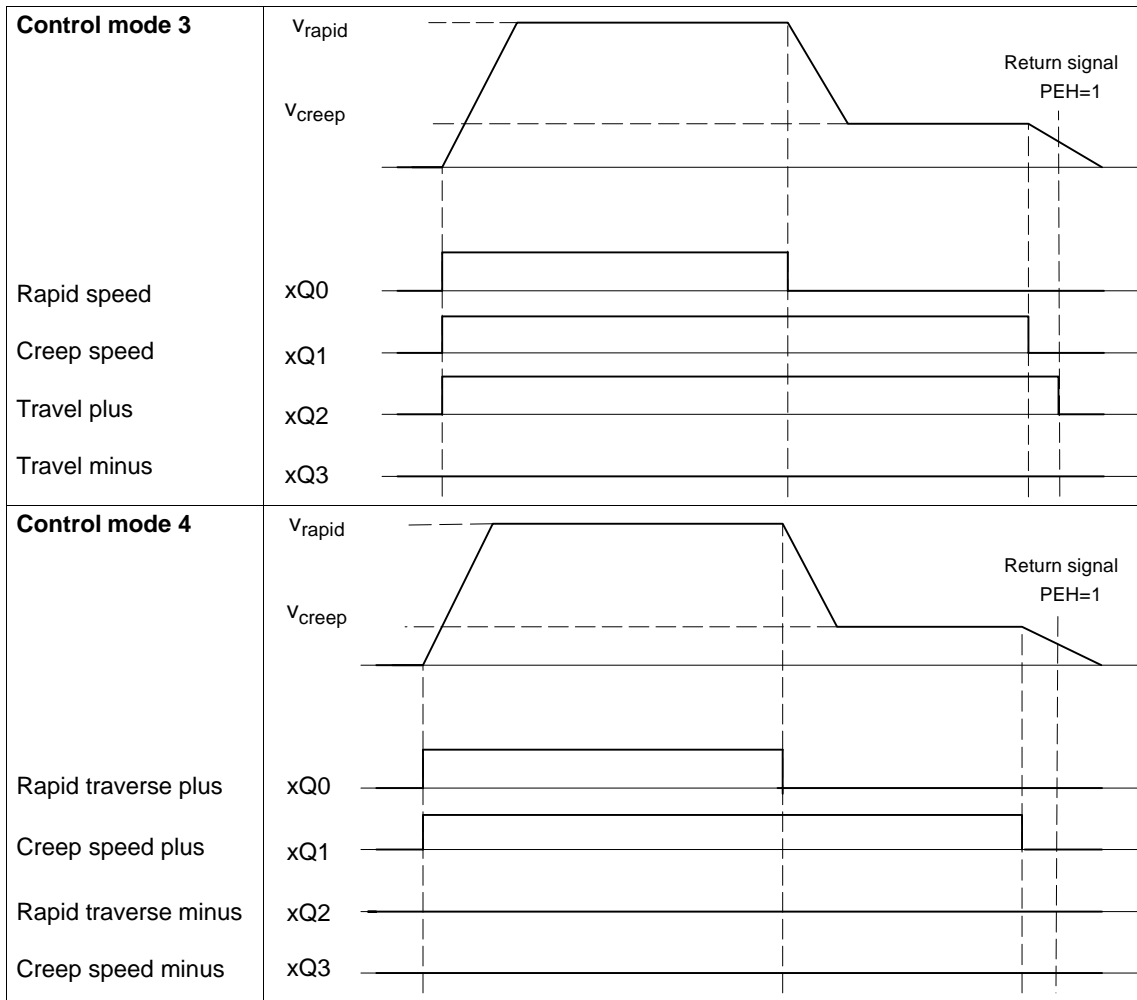

Table 8-1 Table with the States of the 4 Outputs for each Control Mode (x stands for channel 1 and 2)

Control Mode 1	rapid speed		creep speed		Position reached hold (PEH)
	Direction +	Direction -	Direction +	Direction -	
xQ0	1	1	0	0	-
xQ1	0	0	1	1	-
xQ2	1	0	1	0	-
xQ3	0	1	0	1	-
Control Mode 2					
xQ0	1	1	0	0	0
xQ1	0	0	0	0	1
xQ2	1	0	1	0	0
xQ3	0	1	0	1	0

Table 8-1 Table with the States of the 4 Outputs for each Control Mode (x stands for channel 1 and 2)

Control Mode 3	rapid speed		creep speed		Position reached hold (PEH)
	Direction +	Direction -	Direction +	Direction -	
xQ0	1	1	0	0	-
xQ1	1	1	1	1	-
xQ2	1	0	1	0	-
xQ3	0	1	0	1	-
Control Mode 4					
xQ0	1	0	0	0	-
xQ1	1	0	1	0	-
xQ2	0	1	0	0	-
xQ3	0	1	0	1	-

Address	Name	Data Type	Initial Value	Description
100.0	CHGDIF_P	DINT	L#5000	Switchover difference plus Switchover difference minus Switch-off difference plus Switch-off difference minus Range: <ul style="list-style-type: none"> • 1 µm to 1 000 000 000 µm at a resolution of ≥ 1 µm/pulse • 1 µm to 100 000 000 µm at a resolution of < 1 µm/pulse
104.0	CHGDIF_M	DINT	L#5000	
108.0	CUTDIF_P	DINT	L#2000	
112.0	CUTDIF_M	DINT	L#2000	

The “switchover difference” defines the switchover point at which the drive switches over from rapid to creep speed.

The “switch-off difference” defines the switch-off point at which the drive is turned off (at creep speed). From this point onwards, the FM 351 starts monitoring functions.

The values apply for all targets which the FM 351 approaches; with the exception of incremental dimension 255.

Rules

- The values for the plus and the minus direction can be different.
- The switchover difference must be greater than the switch-off difference.
- The switchover difference must be within the working range.
- The switchover difference must be less than the end of the rotary axis.
- The switch-off difference must be greater than the half target range.
- The distance between the switchover point and the switch-off point must be selected so that the drive can switch reliably from rapid to creep speed.
- The distance between the switch-off point and target must be selected so that the drive comes to a stop within the target range.
- The distance between the switchover point, the switch-off point, and the start of the target range must be equivalent to a time of at least 8 ms.

For more detailed information about the arrangement of the ranges, refer to Section 2.2.

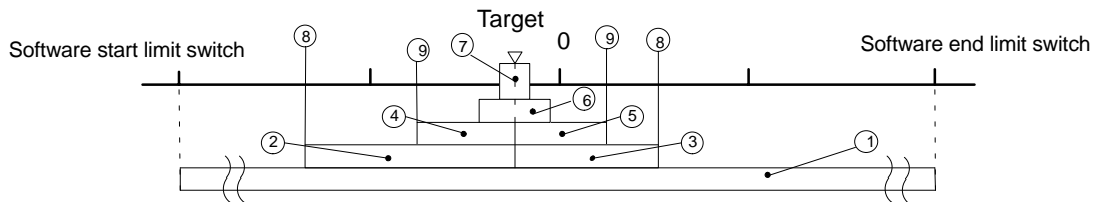

- ① Working range
- ② ③ Switchover diff. plus/minus
- ④ ⑤ Switch-off diff. plus/minus
- ⑥ Stationary range
- ⑦ Target range
- ⑧ Switchover point
- ⑨ Switch-off point

Address	Name	Data Type	Initial Value	Description
76.0	TRG_RANGE	DINT	L#1000	Target range <ul style="list-style-type: none"> 0 = No monitoring Range: <ul style="list-style-type: none"> 1 μm to 1 000 000 000 μm at a resolution of $\geq 1 \mu\text{m/pulse}$ 1 μm to 100 000 000 μm at a resolution of $< 1 \mu\text{m/pulse}$
<p>The target range is located symmetrically around the target. Specifying the value 0 deactivates the monitoring of the target range. On the topic of target approach, you should also refer to Section 9.1 (page 9-2).</p>				

Address	Name	Data Type	Initial Value	Description
84.0	ZSPEED_R	DINT	L#1000	Stationary range <ul style="list-style-type: none"> 0 = No monitoring Range: <ul style="list-style-type: none"> 1 μm to 1 000 000 000 μm at a resolution of $\geq 1 \mu\text{m/pulse}$ 1 μm to 100 000 000 μm at a resolution of $< 1 \mu\text{m/pulse}$
<p>The stationary range is located symmetrically around the target. Whether the drive remains stationary at the approached position or drifts away is monitored. If the stationary range is left without a valid travel job, the FM 351 signals an error. For a value 0 the stationary monitoring is switched off. Recommendation: The stationary range should be greater than the target range. Refer also to Section 9.1 (page 9-2) that illustrates the target approach and the various monitoring functions and messages.</p>				

Address	Name	Data Type	Initial Value	Description
88.0	ZSPEED_L	DINT	L#30000	Stationary speed <ul style="list-style-type: none"> 0 = No monitoring 1 $\mu\text{m/min}$ to 100 000 $\mu\text{m/min}$
<p>The stationary speed is used as a reference speed for the end of a positioning operation. Refer also to Section 9.1 (page 9-2). The value 0 deactivates monitoring of the stationary speed.</p>				

Address	Name	Data Type	Initial Value	Description
80.0	MON_TIME	DINT	L#2000	Monitoring time <ul style="list-style-type: none"> • 0 = No monitoring • 1 to 100 000 ms
<p>Based on the monitoring time, the module monitors the following:</p> <ul style="list-style-type: none"> • The movement of the axis up to the switch-off point. The monitoring time starts at the beginning of a positioning operation and is restarted at each change in the actual value in the direction of travel. • The target approach. The positioning operation must be completed within the monitoring time. The monitoring time is triggered for the last time when the switch-off difference is reached. • The plausibility of the actual values at the switching points. Oscillation of the axis at the switching point leads to operating errors. <p>The value 0 deactivates the monitoring functions.</p> <p>Actual monitoring time</p> <p>For the monitoring time you can specify all values from the defined range.</p> <ul style="list-style-type: none"> • 0: The monitoring is deactivated. • 1 to 100,000 ms: The FM 351 rounds the specified time up to a multiple of 8 ms (module cycle). Ideally, you should therefore enter the monitoring time as a multiple of 8 ms. 				

8.4 Machine Data for the Axis

Axis Data

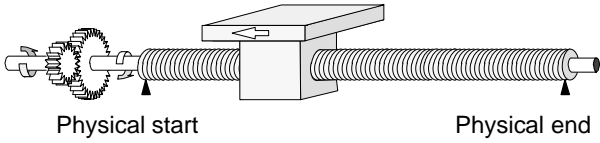
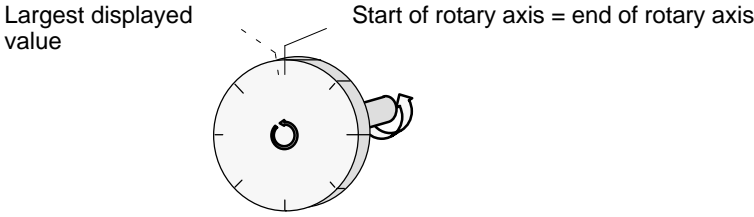
Address	Name	Data Type	Initial Value	Description
12.0	AXIS_TYPE	DINT	L#0	Axis type: 0 = Linear axis 1 = Rotary axis
<p>A linear axis is an axis with a limited physical travel range.</p>  <p>A rotary axis is an axis whose travel range is not restricted by mechanical limit stops.</p> 				

Address	Name	Data Type	Initial Value	Description
16.0	ENDROTAX	DINT	L#100000	End of the rotary axis: Range: <ul style="list-style-type: none"> • 1 μm to 1 000 000 000 μm at a resolution of ≥ 1 μm/pulse • 1 μm to 100 000 000 μm at a resolution of < 1 μm/pulse
<p>The value “end of rotary axis” is the highest theoretical value that the actual value can reach. The highest theoretical value is however never displayed since it is physically the same position as the start of the rotary axis (0).</p> <p>The largest value which is displayed for a rotary axis, has the value: End of the rotary axis [μm] – resolution [μm / pulse] · 1 [pulse] Example: End of the rotary axis 1000 mm, resolution 1000 μm/pulse The display jumps: <ul style="list-style-type: none"> • With a positive direction of rotation from 999 mm to 0 mm. • With a negative direction of rotation from 0 mm to 999 mm. <p>Rotary axis with absolute encoders With a rotary axis with an absolute encoder the rotary axis range (0 to end of rotary axis) must exactly cover the range of the absolute encoder.</p> $\text{End of rotary axis}[\mu\text{m}] = \text{number of revolutions (encoder)} \cdot \frac{\text{dist}[\mu\text{m}]}{\text{revolution}}$ </p>				

Address	Name	Data Type	Initial Value	Description
44.0	REFPT	DINT	L#0	<p>Reference point coordinate:</p> <p>Range:</p> <ul style="list-style-type: none"> –1 000 000 000 μm to 1 000 000 000 μm at a resolution of ≥ 1 μm/pulse –100 000 000 μm to 100 000 000 μm at a resolution of < 1 μm/pulse
<p>Incremental encoder: You require the reference point coordinate for the “reference point approach” mode. If the axis is not synchronized after writing and activating machine data, the actual value is set to the value of the reference point coordinate.</p> <p>Absolute encoder (SSI) You require the reference point coordinate for the mechanical adjustment of the encoder. Read the description of absolute encoder adjustment in Section 8.6 (page 8-19), explaining the interaction of absolute encoder adjustment with other data.</p> <p>The value of the reference point coordinate must be within the working range:</p> <ul style="list-style-type: none"> • Linear axis including the software limit switches • Rotary axis Greater than or equal to 0 and less than the value “end of the rotary axis” ($0 \leq \text{reference point coordinate} < \text{“end of the rotary axis”}$). 				

Address	Name	Data Type	Initial Value	Description
52.0	REFPT_TYPE	DINT	L#0	<p>Type of reference point approach:</p> <p>Ranges:</p> <p>0 = plus, ref. point switch in direction + 1 = plus, ref. point switch in direction – 2 = minus, ref. point switch in direction + 3 = minus, ref. point switch in direction –</p>
<p>With type of reference point approach, you select the conditions for synchronization of the axis.</p> <ul style="list-style-type: none"> • The first statement defines the start direction in which the reference point approach starts. • The second statement defines the location of the zero marker that leads to synchronization relative to the reference point switch. <p>Use of this data is described in Section 9.3 (page 9-11).</p>				

Address	Name	Data Type	Initial Value	Description
99.0	REFPT_SPD	BOOL	TRUE	<p>Start speed for reference point approach</p> <p>0 = rapid speed 1 = creep speed</p>
<p>With this data you select the speed for the start of a reference point approach:</p>				

Address	Name	Data Type	Initial Value	Description
64.0	SSW_STRT	DINT	L#-100000000	Software limit switch start Software limit switch end Range: <ul style="list-style-type: none"> -1 000 000 000 μm to 1 000 000 000 μm at a resolution of ≥ 1 μm/pulse -100 000 000 μm to 100 000 000 μm at a resolution of < 1 μm/pulse
68.0	SSW_END	DINT	L#100000000	

These axis data are used only for a linear axis.

The software limit switches are monitored when the axis is synchronized. The range set by the software end limit switch is known as the **working range**.

The start software limit switch (SLS) must always be less than the end software limit switch (SLE).

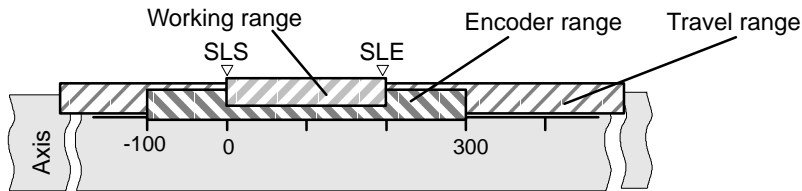

Incremental encoders

Initially, the axis is not synchronized after each FM 351 startup. The set software limit switches are only monitored after synchronization.

Absolute encoder (SSI)

The axis is synchronized once the FM 351 has received a complete, error-free frame for the relevant channel. The software limit switches are monitored from this point in time.

The absolute encoder must cover **at least** the working range including the software limit switches.

Relationship: working range, encoder range, travel range

- The “working range” is the range you specify for your task using the software limit switches.
- The “encoder range” is the range covered by the encoder. With a linear axis, this is placed symmetrically over the working range by the module; in other words, the module shifts the encoder range so that the distances between the software limit switches and the ends of the encoder range are the same (see figure).
- The “travel range” is the range of values that can be processed by the FM 351. It is dependent on the resolution.

8.5 Machine Data for the Encoder

Definition

The encoder supplies position information (see Chapter 10, page 10-1) to the module that evaluates the information and calculates an actual value based on the resolution.

You can only be sure that the calculated actual value of the axis position matches the actual axis position when the information in the machine data of the encoder is correct.

Data in the Parameter DB

Address	Name	Type	Initial Value	Comment
20.0	ENC_TYPE	DINT	L#1	Encoder type and frame length: Range of values: 1 = 5 V incremental 2 = 24 V incremental 3 = SSI 13-bit frame length 4 = SSI 25-bit frame length
With the "frame length", you specify the clock frame output by the FM 351.				

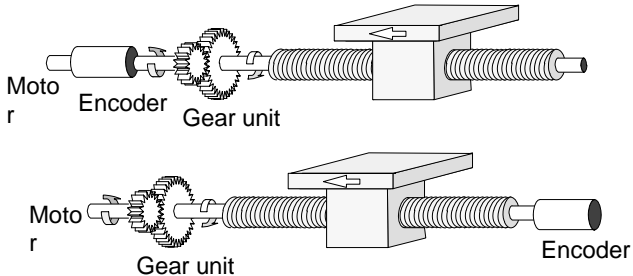
Address	Name	Type	Initial Value	Comment
24.0	DISP_REV	DINT	L#80000	Distance per encoder revolution: Range of values: 1 μm to 1 000 000 000 μm
<p>With the machine data "distance per encoder revolution" you inform the FM 351 of the distance covered by the drive system per encoder revolution.</p> <p>The value "distance per encoder revolution" depends on how the axis is set up and how the encoder is installed. You must take into account all transmission components such as couplings or gearing.</p> <p>Section 8.7 (page 8-22) describes the relationship between the machine data "distance per encoder revolution" and "increments per encoder revolution".</p>				
				

Address	Name	Type	Initial Value	Comment
32.0	INC_REV	DINT	L#500	Increments per encoder revolution: Range of values: 1 to 2 ²⁵
<p>The “increments per encoder revolution” machine data specifies the number of increments output by an encoder per revolution. Based on this value and the machine data “distance per encoder revolution”, the FM 351 can calculate the resolution.</p> <p>Incremental encoders Any value from the range shown can be entered. One increment involves 4x decoding by the module (see also Section 10.1, page 10-2).</p> <p>Absolute encoders For the limits there is a difference between the various encoder models: Only values in steps of a power of two are allowed as input.</p> <ul style="list-style-type: none"> • Single-turn encoders with (number of revolutions = 1) 13-bit frame length: <ul style="list-style-type: none"> – Minimum value = 4 – Maximum value = 8192 • Multiturn encoders (number of revolutions > 1) with 25-bit frame length: <ul style="list-style-type: none"> – Minimum value = 4 – Maximum value = 8192 • Single-turn encoders with 25 bit frame length, no. of revs. = 1 <ul style="list-style-type: none"> – Minimum value = 4 – Maximum value = 2²⁵ <p>Linear scales are assigned parameters as follows as multiturn encoders:</p> <ul style="list-style-type: none"> • Increments per encoder revolution = 8192 • Number of revolutions × 8192 ≥ number of steps of the linear scale 				

Address	Name	Type	Initial Value	Comment
36.0	NO_REV	DINT	L#1	Number of encoder revolutions: Range of values: 1 (single-turn encoder) 2 to 4096 in powers of 2 (multiturn encoder)
<p>The machine data “number of encoder revolutions” is only used for absolute encoders. You use it to define the number of revolutions possible with this encoder.</p> <p>The total number of steps of the encoder does not belong to the machine data. It is calculated as follows: Total number of steps = increments per encoder revolution × number of revolutions</p>				

Address	Name	Type	Initial Value	Comment
40.0	BAUDRATE	DINT	L#0	Baud rate: Range of values: 0 = 188 kHz 1 = 375 kHz 2 = 750 kHz 3 = 1500 kHz
<p>With the baud rate machine data, you define the speed of the data transfer from SSI encoders to the FM 351.</p> <p>This entry has no significance for incremental encoders.</p> <p>The maximum baud rate depends on the cable length:</p> <ul style="list-style-type: none"> • 200 m → 188 kHz • 100 m → 375 kHz • 40 m → 750 kHz • 12 m → 1500 kHz 				

Address	Name	Type	Initial Value	Comment
59.0	CNT_DIR	BOOL	FALSE	Count direction: 0 = normal 1 = inverted
<p>With the machine data “count direction”, you match the direction of the position detection to the direction of axis movement.</p> <p>You must also take into account all the directions of rotation of the transmission elements (for example coupling and gearing).</p> <ul style="list-style-type: none"> • Normal = ascending count pulses (incremental encoder) or encoder values (absolute encoder) correspond to ascending actual position values • Inverted = ascending count pulses (incremental encoder) or encoder values (absolute encoder) correspond to descending actual position values. 				

Address	Name	Type	Initial Value	Comment
63.0	MON_WIRE	BOOL	TRUE	Monitoring functions: 1 = wire break 1 = frame error (must always be 1) 1 = missing pulses
63.1	MON_FRAME	BOOL	TRUE	
63.2	MON_PULSE	BOOL	TRUE	
<p>Wire break</p> <p>When the monitoring is activated, the FM 351 monitors all cables with a 5 V incremental encoder and an absolute encoder. The monitoring detects:</p> <ul style="list-style-type: none"> • Wire break • Short circuit on the separate lines. • Edge-to-edge distance of the count pulses (even with 24 V incremental encoders) <p>When monitoring with a 24 V incremental encoder, you must set a monitoring time MON_TIME > 0.</p> <p>With 5 V incremental encoders without zero markers, you must either deactivate the wire break monitoring or wire the signals N and \bar{N} externally (see Section 10.1).</p> <p>Frame error</p> <p>The module monitors the frame of an absolute encoder (SSI) for the following:</p> <ul style="list-style-type: none"> • Start and stop bit errors <p>Monitoring for frame errors cannot be deactivated with absolute encoders (SSI).</p> <p>Missing pulses (incremental encoder)</p> <p>An incremental encoder must always supply the same number of increments between two consecutive zero markers.</p> <p>The FM 351 checks whether the zero marker of an incremental encoder occurs at the correct encoder status.</p> <p>For encoders without zero markers, you must deactivate error pulse monitoring.</p> <p>You must also deactivate wire break monitoring or connect the zero marker inputs N and \bar{N} externally.</p>				

8.6 Absolute Encoder Adjustment

Definition

With absolute encoder adjustment and the reference point coordinate, there is a defined correlation between the range of values of the encoder and the coordinate system of the axis.

Finding the Correct Absolute Encoder Adjustment

After the initial parameter assignment, further steps are necessary to establish the correct relationship between the encoder and the coordinate system. The procedure is illustrated using the parameter assignment dialogs.

1. Move the axis to a defined, reproducible point to which a unique coordinate is assigned.

This could be, for example, the “end software limit switch”.

2. Call the “set reference point” job with the coordinate of the point defined in 1.

The FM 351 now calculates the correct absolute encoder adjustment for the reference point coordinate in the machine data. This value is displayed in the dialogs of the encoders and in the service dialog of the configuration software.

3. Save the parameter settings with the menu command **File > Save**.
4. Close the parameter dialogs with **File > Exit**.
5. Save the data in HW Config with **Station > Save and Compile**.
6. Download the data in HW Config to the CPU.

Note

You make this adjustment once during installation and startup. The FM 351 is synchronized following parameter assignment during startup as soon as a complete, error-free frame is received from the encoder following startup.

Data in the Parameter DB

Address	Name	Data Type	Initial Value	Description
44.0	REFPT	DINT	L#0	Reference point coordinate Range: <ul style="list-style-type: none"> • $-1\,000\,000\,000\ \mu\text{m}$ to $1\,000\,000\,000\ \mu\text{m}$ at a resolution of $\geq 1\ \mu\text{m/pulse}$ • $-100\,000\,000\ \mu\text{m}$ to $100\,000\,000\ \mu\text{m}$ at a resolution of $< 1\ \mu\text{m/pulse}$
48.0	ENC_ADJ	DINT	L#0	Absolute encoder adjustment: Range: 0 to $(2^{25}-1)$

Example of Absolute Encoder Adjustment

In the example, the following is assumed:

- Reference point coordinate = -125 mm
- Working range of SSW_STRT = - 1000 mm to SSW_END = 1000 mm
- Absolute encoder adjustment = 0
- Encoder range = 2048 increments with a resolution of 1 mm/pulse
- The absolute encoder used cannot be exactly adjusted mechanically and also does not have the option of setting the encoder value.

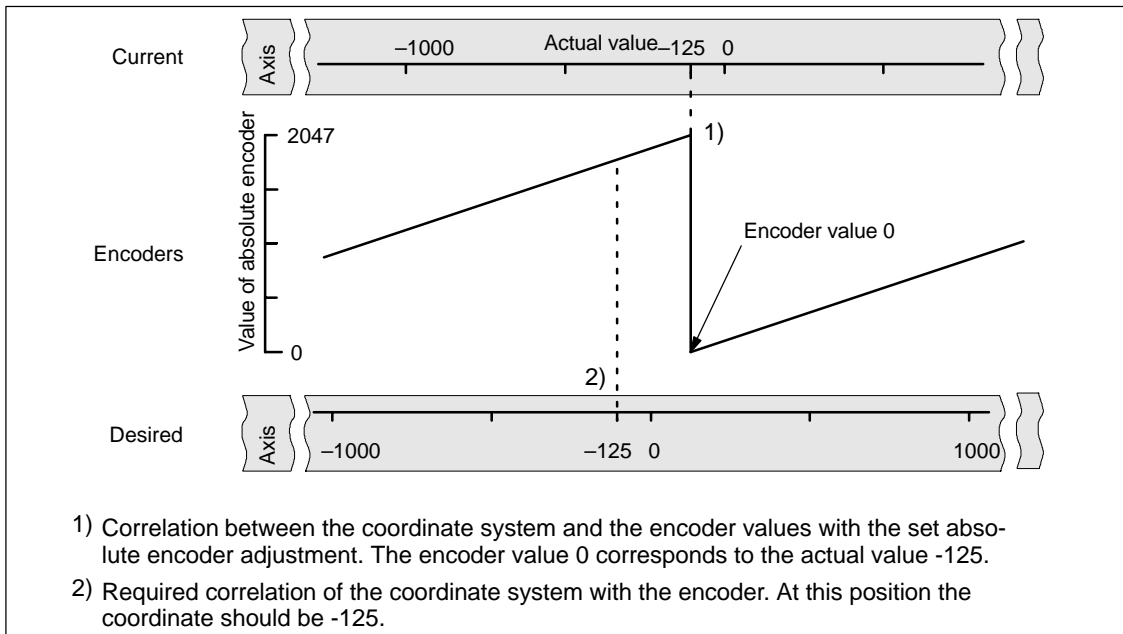

Result After Setting the Reference Point

After “set reference point”, the relationship is as follows:

The reference point coordinate on the axis (-125) is assigned to the encoder value (1798) calculated from the absolute encoder adjustment.

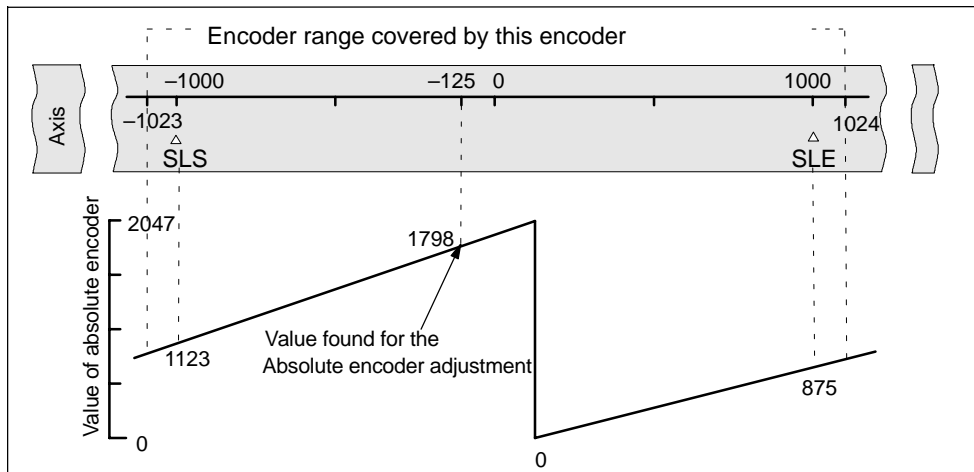

The encoder supplies 2048 defined values. The working range is defined by the software limit switches. Due to the selected resolution of 1 mm per pulse, the encoder can, however, cover a larger working range than intended with the software limit switches.

With the set resolution the working range is already covered with 2001 values. Therefore, in the example there are 47 pulses "left over" which lie symmetrically about the working range.

Alternative: Mechanical Adjustment of an Encoder

You can obtain a correct relationship between the coordinate system and the encoder as follows:

1. Move the axis to a reproducible position (for example the software limit switch start).
2. Enter this coordinate value in the machine data as the reference point coordinate.
3. Read the encoder value displayed at this position in the service dialog of the configuration software.
4. Enter this value as the absolute encoder adjustment in the machine data.

A correct actual value is then always displayed after parameters have been set.

Instead of steps 3. and 4., you can also set the encoder to zero with "Reset" (if this exists) and enter the value "0" as the absolute encoder adjustment in the machine data.

8.7 Resolution

Definition

The resolution specifies the distance corresponding to one **pulse**. It is a measure of the accuracy of the positioning and also determines the maximum possible travel range of the FM 351.

The resolution (RES) is calculated as illustrated in the following table:

	Incremental Encoders	Absolute Encoders
Input values	<ul style="list-style-type: none"> • Displacement per encoder rev. • Increments per encoder revolution: <ul style="list-style-type: none"> – Pulse evaluation: 4x – 1 increment = 4 pulses 	<ul style="list-style-type: none"> • Displacement per encoder rev. • Increments per encoder revolution: <ul style="list-style-type: none"> – 1 increment = 1 pulse
Calculation	$\text{RES} = \frac{\text{dist}}{\frac{\text{encoder rev}}{\text{pulses}} \cdot \text{encoder rev}}$	

Note

All position information is rounded up to the integral multiple of the resolution. This allows you to distinguish between the entered and the used values.

Range of Values of the Resolution

The selected system of units decides the range of values for the resolution:

System of Units	Specified in...	Range for the Resolution
mm	10^{-3} mm	$0.1 \cdot 10^{-3}$ $1000 \cdot 10^{-3}$ mm/pulse
inches	10^{-4} inches	$0.1 \cdot 10^{-4}$ $1000 \cdot 10^{-4}$ inches/pulse
degrees	10^{-4} degrees	$0.1 \cdot 10^{-4}$ $1000 \cdot 10^{-4}$ degrees/pulse
	10^{-3} degrees	$0.1 \cdot 10^{-3}$ $1000 \cdot 10^{-3}$ degrees/pulse
	10^{-2} degrees	$0.1 \cdot 10^{-2}$ $1000 \cdot 10^{-2}$ degrees/pulse

Example

- An incremental encoder has the following data:
 - Increments per encoder revolution: 5000
 - Distance per encoder revolution: 1000 mm
 - 1 increment = 4 pulses

This results in the following resolution (4x decoding):

$$\begin{aligned} \text{Resolution} &= \frac{1000 \text{ mm}}{5000 \text{ increments}} = 0.2000 \frac{\text{mm}}{\text{increment}} = 0.2000 \frac{\text{mm}}{4 \text{ pulses}} \\ &= 0.0500 \frac{\text{mm}}{\text{pulse}} \end{aligned}$$

- An SSI encoder has the following data:
 - Increments per encoder revolution: 4096
 - Distance per encoder revolution: 1000 mm
 - 1 increment = 1 pulse

This results in the following resolution:

$$\text{Resolution} = \frac{1000 \text{ mm}}{4096 \text{ increments}} = 0.2441 \frac{\text{mm}}{\text{increment}} = 0.2441 \frac{\text{mm}}{\text{pulse}}$$

Relationship Between Travel Range and Resolution

The travel range is limited by the numeric representation in the FM 351. The number representation varies depending on the resolution. Therefore, make sure that you are always within the permissible limits when specifying values.

The maximum travel range is represented in the table below:

Resolution (RES) is in the range	Maximum travel range
$0.1 \mu\text{m}/\text{pulse} \leq \text{RES} < 1 \mu\text{m}/\text{pulse}$	$-10^8 \mu\text{m}$ to $10^8 \mu\text{m}$ (–100 m to +100 m)
$1 \mu\text{m}/\text{pulse} \leq \text{RES} \leq 1000 \mu\text{m}/\text{pulse}$	$-10^9 \mu\text{m}$ to $10^9 \mu\text{m}$ (–1000 m to +1000 m)

8.8 Incremental dimensions

Definition

Incremental dimensions are targets that can be approached by the FM 351 in the **absolute/relative incremental approach** modes.

Requirements for Incremental Dimensions

The positioning target must be at a location corresponding to at least half the target range before the software limit switch.

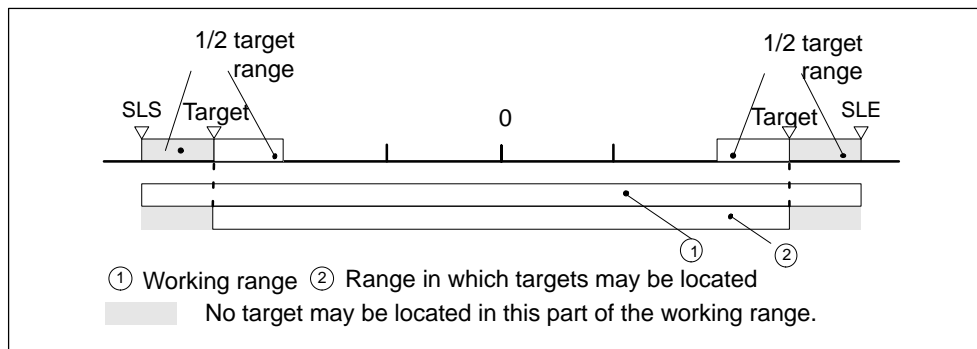

Figure 8-1 Limits for Entry of Incremental Dimensions

8.8.1 Incremental dimension number 1 to 100

You can enter a maximum of 100 incremental dimensions in a table that are valid both for the **relative incremental approach** and the **absolute incremental approach** modes.

Note that the FM 351 does not allow any negative values for the **relative incremental approach**. The values are interpreted by the FM 351 depending on the direction of movement as positive or negative differences.

Note

The entry is made in the appropriate unit for the selected system of units. Make sure that the decimal places are correct.

Example:

Incremental dimension	800 mm
Units	10^{-3} mm
Entry in the parameter DB	800000

Recommendation: Define separate ranges for relative and absolute increments in the incremental dimension table.

Data Used in the Channel DB

Address	Name	Type	Initial Value	Comment
35.4	TRGL1WR_EN	BOOL	FALSE	1 = write incremental dimension table 1 (incremental dimensions 1 ... 50)
35.5	TRGL2WR_EN	BOOL	FALSE	1 = write incremental dimension table 2 (incremental dimensions 51 ... 100)
36.6	TRGL1RD_EN	BOOL	FALSE	1 = read incremental dimension table 1 (incremental dimensions 1 ... 50)
36.7	TRGL2RD_EN	BOOL	FALSE	1 = read incremental dimension table 2 (incremental dimensions 51 ... 100)

Data Used in the Parameter DB

Address	Name	Type	Initial Value	Comment
120.0	TRGL1.TRG[1]	DINT	L#0	Incr. dim. number 1
.	.	.	.	Incr. dim. table 1
316.0	TRGL1.TRG[50]	DINT	L#0	Incr. dim. number 50
320.0	TRGL2.TRG[51]	DINT	L#0	Incr. dim. number 51
.	.	.	.	Incr. dim. table 2
516.0	TRGL2.TRG[100]	DINT	L#0	Incr. dim. number 100

8.8.2 Incremental Dimension Number 254

You can also use this incremental dimension number 254 to specify the distance independent of the incremental dimension table. The entries in the parameter DB are valid for the switchover and switch-off differences for this incremental dimension.

Data Used in the Channel DB

Address	Name	Type	Initial Value	Comment
36.2	TRG252_254_EN	BOOL	FALSE	1 = write incremental dimension for incremental dimension number 254
96.0	TRG252_254	DINT	L#0	Incremental dimension for incremental dimension number 254

Data Used in the Parameter DB

Address	Name	Type	Initial Value	Comment
100.0	CHGDIF_P	DINT	L#5000	Switchover difference plus
104.0	CHGDIF_M	DINT	L#5000	Switchover difference minus:
108.0	CUTDIF_P	DINT	L#2000	Switch-off difference plus
112.0	CUTDIF_M	DINT	L#2000	Switch-off difference minus

8.8.3 Incremental Dimension Number 255

Incremental dimension number 255 also allows you to set the distance.

You transfer the switch-off differences and the switchover differences together with the incremental dimension. In contrast to the other incremental dimensions, incremental dimension 255 uses the value for the switch-off and switchover difference specified in the channel DB. The entries from the machine data have no validity for this incremental dimension.

Data Used in the Channel DB

Address	Name	Type	Initial Value	Comment
36.3	TRG255_EN	BOOL	FALSE	1 = write incremental dimension for incremental dimension number 255
100.0	TRG255	DINT	L#0	Incremental dimension for incremental dimension number 255
104.0	CHGDIF255	DINT	L#0	Switchover differences for incremental dimension number 255
108.0	CUTDIF255	DINT	L#0	Switch-off differences for incremental dimension number 255

Modes and Jobs

9

Chapter Overview

Section	Topic	Page
9.1	End of Positioning	9-2
9.2	Jogging Mode	9-8
9.3	Reference Point Approach Mode	9-11
9.4	Incremental Approach Mode	9-17
9.5	Set Actual Value / Cancel Set Actual Value	9-23
9.6	Set Reference Point	9-25
9.7	Loop Traverse Mode	9-27
9.8	Enable Input	9-30
9.9	Read Position Data	9-31
9.10	Read Encoder Data	9-32
9.11	Return Signals for Positioning	9-33
9.12	Return Signals for Diagnostics	9-34

9.1 End of Positioning

Definition

The end of a positioning operation is indicated by the return signal WORKING = 0. This can be achieved in three different ways:

- Final target approach
- Terminating
- Aborting

Monitoring Functions

In the last phase of a positioning operation, the following monitoring functions are active:

- Monitoring time

The monitoring time is retriggered for the last time at the switch-off point and ceases to be valid at the end of the positioning operation.

During this time, the end of the positioning operation must be reached, otherwise the outputs are deactivated and the operating error “error in target approach” (error number 5) is signaled.

- Monitoring of the target range

The FM 351 places a symmetrical range either side of a target which defines the positioning accuracy of your application. The axis must become stationary during a target approach within this range. Setting a value of “0” cancels the tolerance during target approach.

- Monitoring of the stationary speed

The stationary speed is used to check that the drive becomes stationary within the target range. After reaching the switch-off point, the drive is monitored to detect when the speed falls below this setting.

The drive speed must fall below the stationary speed within the target range, otherwise the FM 351 signals the operating error “target range passed” (error number 10).

The speed falling below the stationary speed is monitored only once per target approach.

Note that the speed can fall below the stationary speed used by the module to detect the speed when the axis moves at an extremely slow positioning speed (less than 2 pulses per 8 ms).

- Monitoring of the stationary range

On completion of a positioning operation, a monitoring function detects whether the drive remains stationary at the target position or whether it drifts away from this position.

The stationary range is monitored

- after the FM 351 has returned the "PEH" signal,
- when the monitoring time is exceeded,
- when the speed falls below the stationary speed.

If the drive leaves the stationary range without a valid travel job, the FM 351 indicates the operating error "stationary range exited" (error number 6).

Target Approach

In the "absolute/relative incremental approach" modes, the target approach begins when the switch-off point is reached. At this point, the drive is turned off and the FM 351 starts the monitoring functions.

Depending on the monitoring functions you have activated, there are various situations in which the return signal "PEH (POS_RCD)" is generated. Positioning is aborted as soon as the generation of the "PEH (POS_RCD)" return signal does not take place.

1. You have set the following parameters:

- Target range (TRG_RANGE) > 0
- Stationary speed (ZSPEED_L) > 0
- Monitoring time (MON_TIME) > 0

PEH is generated when the speed falls below the stationary speed and the target range is reached. Which condition is satisfied first is irrelevant.

PEH is not generated when the actual value does not reach the target range within the monitoring time or the target range is passed without the speed falling below the stationary speed.

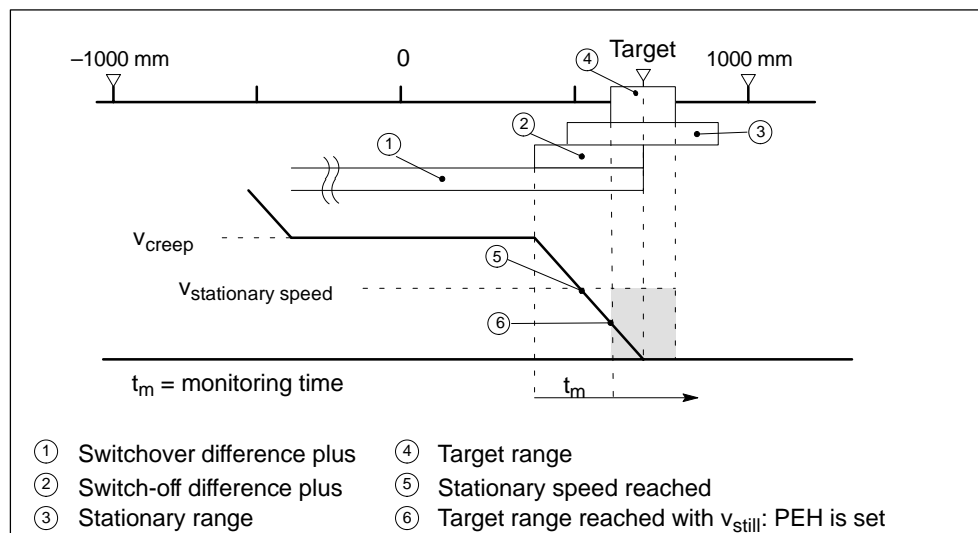

Figure 9-1 Final Target Approach of an Incremental Approach

2. You have set the following parameters:

- Target range (TRG_RANGE) > 0
- Stationary speed (ZSPEED_L) = 0
- Monitoring time (MON_TIME) > 0

PEH is generated when the target range is reached.

PEH is not generated if the actual value does not reach the target range within the monitoring time.

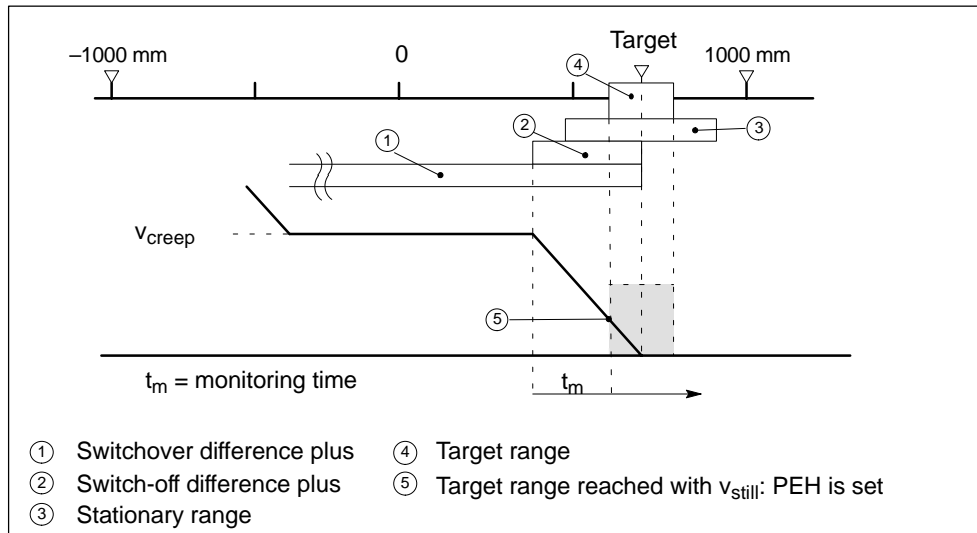

Figure 9-2 Final Target Approach of an Incremental Approach

3. You have set the following parameters:

- Target range (TRG_RANGE) = 0
- Stationary speed (ZSPEED_L) > 0
- Monitoring time (MON_TIME) > 0

PEH is generated when the speed falls below the stationary speed and the target is reached.

PEH is not generated if the actual value does not reach the target during the monitoring time or the target range is passed without the speed falling below the stationary speed.

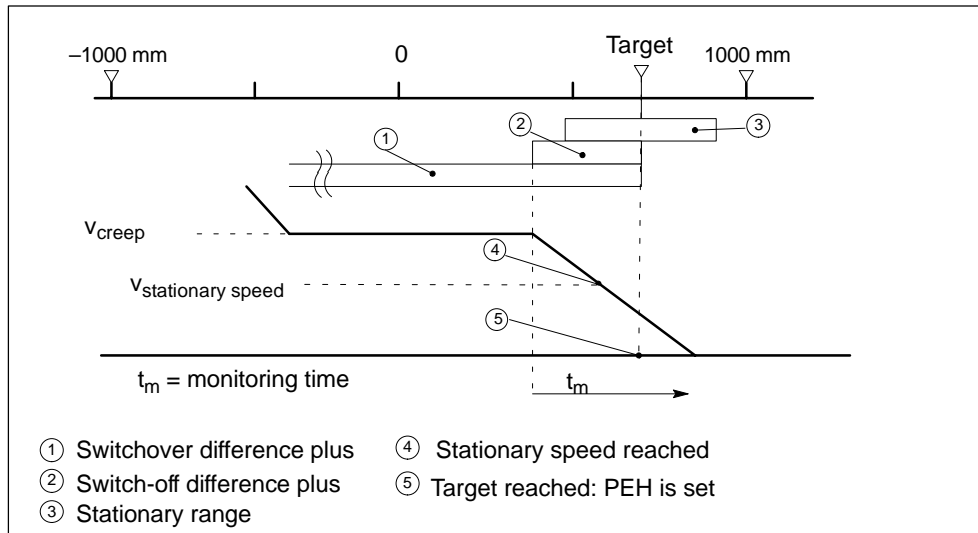

Figure 9-3 Final Target Approach of an Incremental Approach

4. You have set the following parameters:

- Target range (TRG_RANGE) = 0
- Stationary speed (ZSPEED_L) = 0
- Monitoring time (MON_TIME) > 0

PEH is generated when the target is reached.

PEH is not generated if the actual value does not reach the target within the monitoring time.

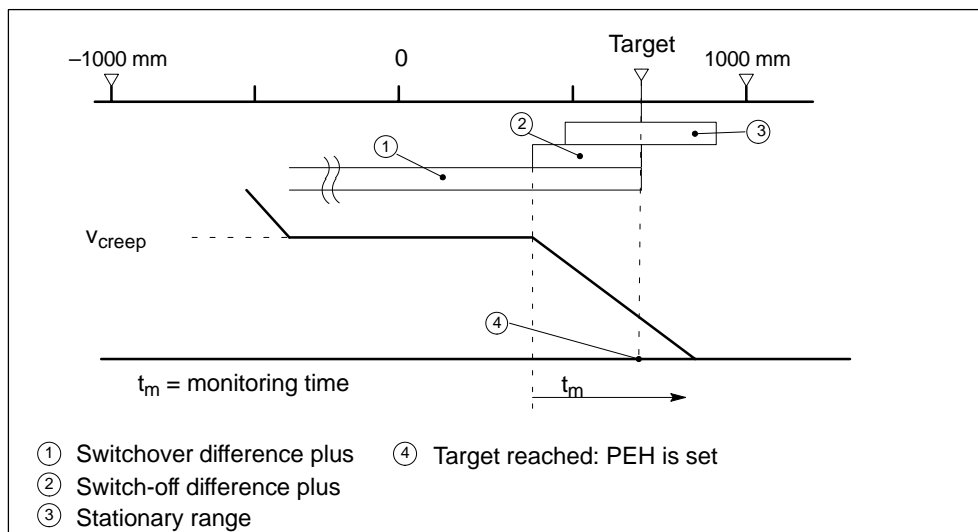

Figure 9-4 Final Target Approach of an Incremental Approach

5. You have set the following parameters:

- Target range (TRG_RANGE) ≥ 0
- Stationary speed (ZSPEED_L) ≥ 0
- Monitoring time (MON_TIME) = 0

In this situation, if the axis becomes stationary during positioning before the target range is reached, the end of positioning is not detected. PEH is not generated and the WORKING return signal remains set. You can abort the positioning operation only by clearing the drive enable signal (DRV_EN = 0).

Terminating without a Specified Target

Terminating means that the positioning operation is stopped after changing from rapid to creep speed while maintaining the differences.

Positioning is terminated when

- The FM 351 receives a STOP signal (STOP=1)
- The “jogging” and “reference point approach” modes are exited
- Operator error occurred

The “PEH (POS_RCD)” return signal is not set. The sequences are analogous to target approach.

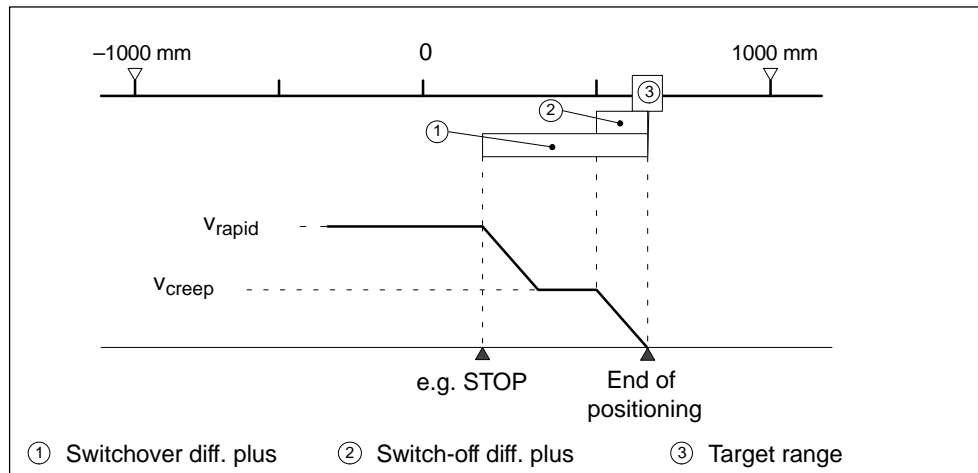

Figure 9-5 End of Positioning

Aborting

Aborting means that the positioning operation is stopped immediately changing from rapid or creep speed to stationary ignoring the switchover and switch-off differences. All the relevant outputs of the control mode are deactivated immediately and the following settings made:

- Incremental dimension = actual value
- Remaining distance = zero

Positioning is aborted in the following situations:

- The drive enable signal is cleared (DRV_EN=0)
- The CPU changes to STOP
- Diagnostic errors or any operating errors except for operating error “target range passed” (error number 9) occur.

The “PEH (POS_RCD)” return signal is not set in the “incremental approach” mode.

If you have set the stationary speed parameter, the stationary monitoring becomes active once the speed falls below the stationary speed. If you have not set the stationary speed parameter, the stationary monitoring becomes active when the outputs are deactivated.

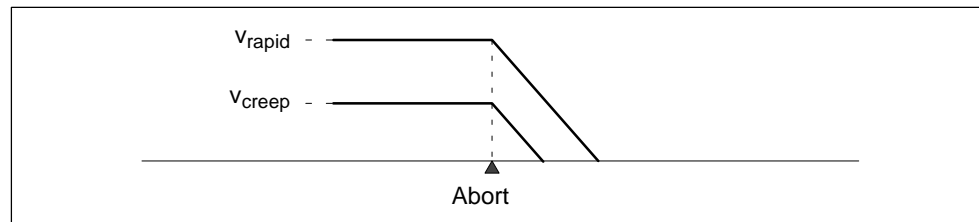

Figure 9-6 Aborting a Positioning Operation

Data Used in the Parameter DB

Address	Name	Type	Initial Value	Comment
76.0	TRG_RANGE	DINT	L#1000	Target range
80.0	MON_TIME	DINT	L#2000	Monitoring time
84.0	ZSPEED_R	DINT	L#1000	Stationary range
88.0	ZSPEED_L	DINT	L#30000	Stationary speed

Return signals in the Channel DB

Address	Name	Type	Initial Value	Comment
23.1	WORKING	BOOL	FALSE	1 = positioning active
25.7	POS_RCD	BOOL	FALSE	1 = position reached

9.2 Jogging Operating Mode

Definition

In the “jogging” mode, you move the drive in a specific direction by pressing a button. You must install one button for each direction (plus and minus). You can use the “jogging” mode both for a synchronized and for an unsynchronized axis.

Requirement

You have set the parameters for the axis.

Sequence of the “Jogging” Mode

1. Set the control signal for the “jogging” mode (MODE_IN=1).
2. Set the control signal for drive enable (DRV_EN=1).
3. Set the function switch for “do not evaluate enable input” (EI_OFF=1) or wire up the enable input for the relevant channel.
4. Enter the start speed.
 - Rapid speed (MODE_TYPE=1)
 - Creep speed (MODE_TYPE=0)
5. Set the control signal for the direction of travel plus or minus (DIR_P=1 or DIR_M=1).
6. Call FC ABS_CTRL.

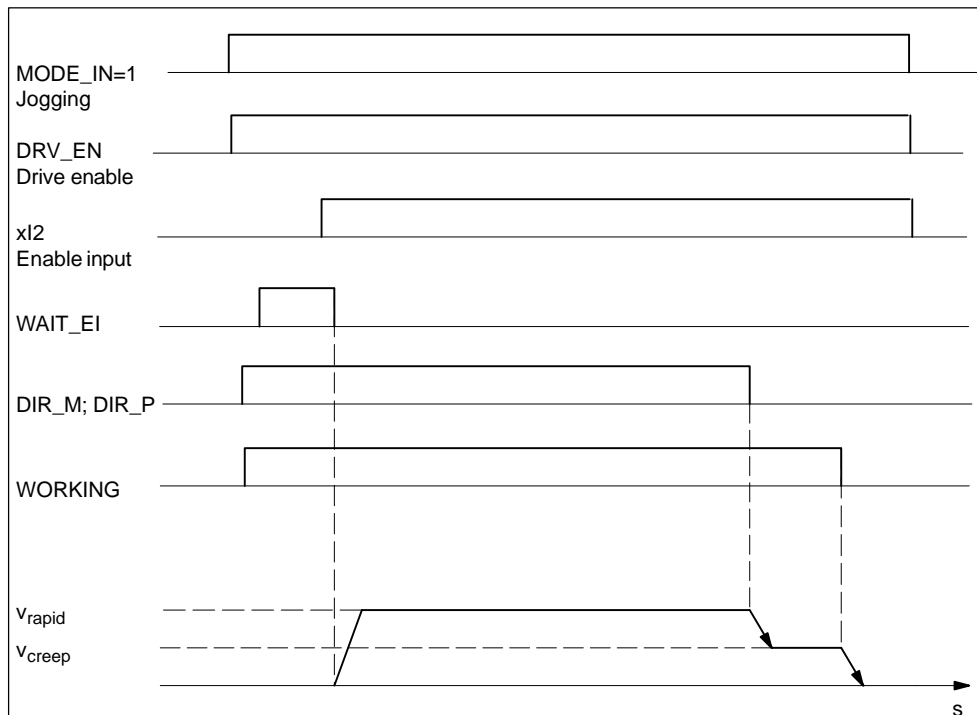

Figure 9-7 Example of the “Jogging” Mode

Data Used in the Channel DB

Address	Name	Type	Initial Value	Comment
15.2	DIR_M	BOOL	FALSE	1 = direction minus
15.3	DIR_P	BOOL	FALSE	1 = direction plus
15.7	DRV_EN	BOOL	FALSE	1 = activate drive enable
16.0	MODE_IN	BYTE	B#16#0	1 = jogging
17.0	MODE_TYPE	BYTE	B#16#0	1 = rapid speed 0 = creep speed
23.0	ST_ENBLD	BOOL	FALSE	1 = start enabled
23.1	WORKING	BOOL	FALSE	1 = positioning active
23.2	WAIT_EI	BOOL	FALSE	1 = axis waiting for ext. enable
34.2	EI_OFF	BOOL	FALSE	1 = do not evaluate enable input

Terminating Jogging

The “jogging” mode is terminated in the following situations:

- When you release the “jogging” button (DIR_M or DIR_P=0)
- When the FM 351 receives a STOP signal (STOP=1)
- When the actual value of a synchronized linear axis reaches the limit of the working range. Travel is then only possible in the opposite direction.

After terminating the positioning operation, travel can be continued in either direction.

Aborting Jogging

The “jogging” mode is aborted in the following situations:

- The drive enable signal is cleared (DRV_EN=0)
- A travel range limit is passed on a linear axis.

Working Range Limits of a Linear Axis

The limits for the “jogging” mode differ depending upon whether an axis is synchronized or not.

Table 9-1 Jogging with a Synchronized and Non-Synchronized Axis

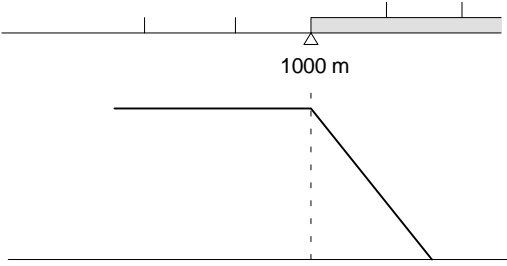
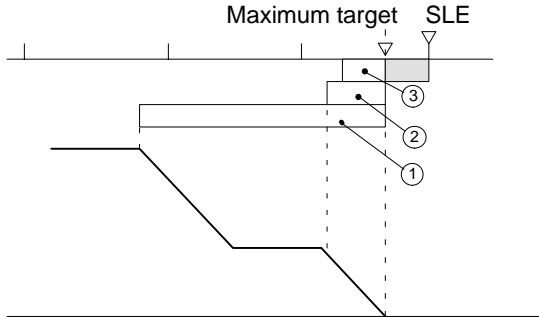
Axis is not synchronized	Axis is synchronized.
<p>If the travel range limit is passed during jogging:</p> <ul style="list-style-type: none"> the indicated actual value is no longer valid positioning is aborted.  <p>1000 m</p> <p>■ The indicated actual value is no longer valid</p>	<p>Jogging means positioning on targets located at a distance from the software limit switches corresponding to the entire target range.</p> <p>The working range limits are calculated as follows:</p> <ul style="list-style-type: none"> SLE- 1/2 target range for the end of the linear axis in the plus direction SLS+ 1/2 target range for the end of the linear axis in the minus direction <p>If you do not release the button earlier, the FM 351 terminates at a target point which is located at a distance corresponding to half the target range before the relevant software limit switch. All ranges required to ensure correct termination, are placed around this target point by the FM 351.</p>  <p>Maximum target SLE</p> <p>③ ② ①</p> <p>■ Part of the working range in which no target position may be located.</p>

① Switchover diff. plus

② Switch-off diff. plus

③ 1/2 target range

9.3 Reference Point Approach Mode

Definition

With the “reference point approach” mode, you can synchronize the axis based on a repeated external event.

Requirements

- An incremental encoder with zero marker.
- You have set the parameters for the axis.

Connection	Channel 1	Channel 2
Reference-point switch	Digital input 1I0	Digital input 2I0
	The reference-point switch should be designed so that the drive can brake reliably from rapid to creep speed in the region of the switch.	
Reversing switch	Digital input 1I1	Digital input 2I1
	When you set the parameters, make sure that the start of the reference point approach is set in the direction of the reversing switch. Only then can you be sure that the reference-point switch is always found.	
Enable input	Digital input 1I2	Digital input 2I2

Sequence of the “Reference Point Approach” Mode

1. Enter the value for the reference point coordinate in the parameter DB (REFPT).
2. Enter the type of “reference point approach” in the parameter DB.

Here, you have the following options:

Start in direction...	For Synchronization use...	
plus	The first zero marker in the direction plus after leaving the reference point switch	REFPT_TYPE=0
plus	The first zero marker in the direction minus after leaving the reference point switch	REFPT_TYPE=1
minus	The first zero marker in the direction plus after leaving the reference point switch	REFPT_TYPE=2
minus	The first zero marker in the direction minus after leaving the reference point switch	REFPT_TYPE=3

3. Enter the start speed.
 - Rapid (REFPT_SPD=0)
 - Creep (REFPT_SPD=1)
4. Write and activate the machine data.
5. Set the control signal for the “reference point approach” mode (MODE_IN=3).
6. Set the control signal for drive enable (DRV_EN=1).
7. Set the function switch for “do not evaluate enable input” (EI_OFF=1) or wire up the enable input for the relevant channel.
8. Set the control signal for the travel direction plus or minus or the start signal (DIR_P=1, DIR_M=1 or START=1)
9. Call FC ABS_CTRL.

Table 9-2 Start Commands for a Reference Point Approach

Start Command	Task	Remark
DIR_P	The drive starts in the direction of more positive values; in other words, it moves in the direction of the end of the travel range.	If a negative direction is entered in the machine data, the FM 351 signals an operating error. No reference point approach is carried out.
DIR_M	The drive starts in the direction of more negative values; in other words, it moves in the direction of the start of the travel range.	If a positive direction is entered in the machine data, the FM 351 signals an operating error. No reference point approach is carried out.
START	The drive starts in the direction entered in the machine data.	

Note

The following applies for a rotary axis: The reproducibility of the reference point is only guaranteed if an integral ratio exists between the value **end of rotary axis** and the value **distance per encoder revolution**.

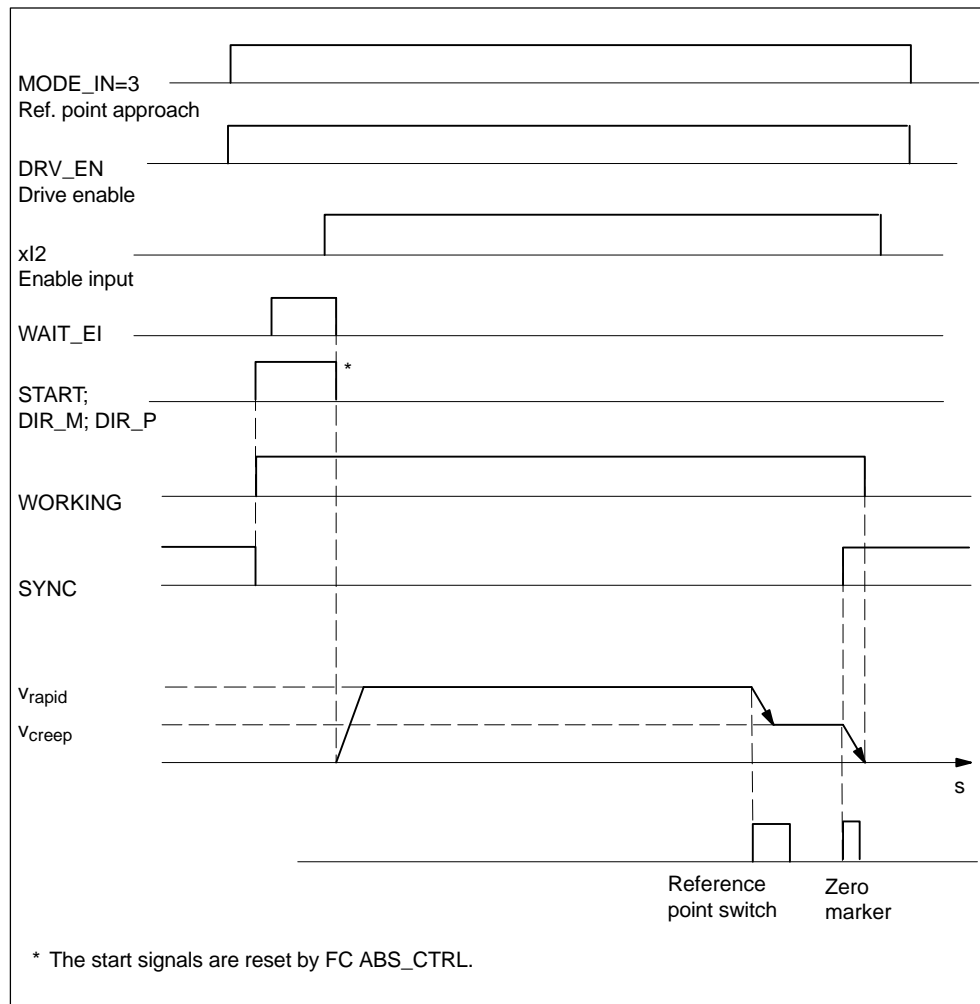

Figure 9-8 Example of the "Reference Point Approach" Mode

Data Used in the Channel DB

Address	Name	Type	Initial Value	Comment
15.0	START	BOOL	FALSE	1 = start positioning
15.2	DIR_M	BOOL	FALSE	1 = direction minus
15.3	DIR_P	BOOL	FALSE	1 = direction plus
15.7	DRV_EN	BOOL	FALSE	1 = activate drive enable
16.0	MODE_IN	BYTE	B#16#0	3 = reference point approach
23.0	ST_ENBLD	BOOL	FALSE	1 = start enabled
23.1	WORKING	BOOL	FALSE	1 = positioning active
23.2	WAIT_EI	BOOL	FALSE	1 = axis waiting for ext. enable

Address	Name	Type	Initial Value	Comment
25.0	SYNC	BOOL	FALSE	1 = axis is synchronized
34.2	EI_OFF	BOOL	FALSE	1 = do not evaluate enable input

Data Used in the Parameter DB

Address	Name	Type	Initial Value	Comment
44.0	REFPT	DINT	L#0	Reference-point coordinate
52.0	REFPT_TYPE	DINT	L#0	Type of reference point approach
99.0	REFPT_SPD	BOOL	TRUE	Start speed for reference point approach 0 = rapid 1 = creep

Effects of the Mode

- As soon as travel starts, the synchronization is canceled.
- The actual position is set to the value of the reference coordinate when the “SYNC” return signal is set.
- The working range is fixed on the axis.
- The individual points within the working range retain their original value, are however located at new positions.

Aborting the Reference Point Approach

The “reference point approach” mode is aborted in the following situations:

- The drive enable signal is cleared (DRV_EN=0)
- A travel range limit is passed on a linear axis.

Reference Point Approach Depending on the Start Position

The actual situation in a reference point approach depends on the following:

- the position of the drive at the start of a reference point approach
- the selected start direction
- the set position of the zero marker for the reference point switch.

Table 9-3 explains all the situations for REFPT_TYPE 0 and 1. The diagrams apply analogously to REFPT_TYPE 2 and 3.

Table 9-3 Options for a Reference Point Approach

Conditions for a Reference Point Approach	Sequence of a Reference Point Approach
<p>Example of a reference point approach (REFPT_TYPE=0):</p> <ul style="list-style-type: none"> • Start direction is plus. • Position of the zero marker from the reference point switch is set in the plus direction. 	
<p>Example of a reference point approach (REFPT_TYPE=1):</p> <ul style="list-style-type: none"> • Start direction is plus. • Position of the zero marker from the reference point switch is set in the minus direction. 	
<p>Example of a reference point approach (REFPT_TYPE=0):</p> <ul style="list-style-type: none"> • The start direction must be set in the plus direction. • Position of the zero marker from the reference point switch is set in the plus direction. • The reverse switch is more positive than the reference-point switch. 	

R = Direction REF = Reference-point REV= Reversing Z = Encoder zero mark
 SYNC = Synchronization was achieved.

Table 9-3 Options for a Reference Point Approach, continued

Conditions for a Reference Point Approach	Sequence of a Reference Point Approach
<p>Example of a reference point approach (REFPT_TYPE=1):</p> <ul style="list-style-type: none"> • Start direction is plus. • Position of the zero marker from the reference point switch is set in the minus direction. • Start position for the reference point approach is at the reference-point switch. 	
<p>Example of a reference point approach (REFPT_TYPE=0):</p> <ul style="list-style-type: none"> • Start direction is plus. • Position of the zero marker from the reference point switch is set in the plus direction. • The reverse switch is more positive than the reference-point switch. 	
<p>Example of a reference point approach (REFPT_TYPE=0):</p> <ul style="list-style-type: none"> • Start direction is plus. • Position of the zero marker from the reference point switch is set in the plus direction. • Start speed = creep speed 	

R = Direction REF = Reference-point REV= Reversing Z = Encoder zero mark
 SYNC = Synchronization was achieved.

9.4 Incremental Operating Mode

Definition

With the “incremental approach”, the FM 351 can do the following:

- Move the drive to **absolute** targets,
- Move the drive **relatively** by a distance in a specified direction.

The target or the relative distances are specified for the FM 351 as incremental dimensions. You can enter a maximum of 100 incremental dimensions in a table that are valid both for the **relative incremental approach** and the **absolute incremental approach** modes. Regardless of the incremental dimension table, you can specify the distance using the incremental dimension 254 and 255 (see Section 8.8, page 8-24).

Requirements

- You have set the parameters for the axis.
- The axis must be synchronized.
- The incremental dimensions must exist on the module.

Interpretation of the Incremental Dimensions

Depending on which incremental approach you select, the FM 351 interprets the information differently.

- Absolute incremental mode: The incremental dimensions are interpreted as an absolute target position.
- Relative incremental mode: The incremental dimensions are interpreted as a relative distance from the start position.

Note

For the “relative incremental approach” mode, only positive incremental dimensions are permitted. The sign for the incremental dimensions is obtained from the specified direction DIR_P or DIR_M.

Sequence of the “Incremental Approach” Mode with Incr. Dim. Number 1 – 100

Absolute Incremental Approach	Relative Incremental Approach
Incremental dimension number 1 – 100	
1. Set the control signal for the “absolute incremental approach” mode (MODE_IN=5).	1. Set the control signal for the “relative incremental approach” mode (MODE_IN=4).
2. Enter the incremental dimensions in the tables (TRGL1; TRGL2).	
3. Write the incremental dimension tables (TRGL1/2WR_EN=1).	
4. Set the control signal for drive enable (DRV_EN=1).	
5. Set the function switch for “do not evaluate enable input” (EI_OFF=1) or wire up the enable input for the relevant channel.	
6. Enter the incremental dimension number (MODE_TYPE=1...100).	
7. Set the control signal: <ul style="list-style-type: none"> • Linear axis: <ul style="list-style-type: none"> – START: The only possible direction is determined by the target and the current actual value. • Rotary axis <ul style="list-style-type: none"> – START: The target is approached along the shortest path. – DIR_P; Start in plus direction – DIR_M; Start in minus direction 	7. Set the control signal: <ul style="list-style-type: none"> • Linear axis: <ul style="list-style-type: none"> – DIR_P; Start in plus direction – DIR_M; Start in minus direction • Rotary axis <ul style="list-style-type: none"> – DIR_P; Start in plus direction – DIR_M; Start in minus direction
8. Call FC ABS_CTRL.	
Steps 2 and 3 are only required if no incremental dimensions already exist or if you want to modify the existing incremental dimensions.	

Sequence of the “Incremental Approach” Mode with Incr. Dim. Number 254

Absolute Incremental Approach	Relative Incremental Approach
Incremental Dimension Number 254	
1. Set the control signal for the “absolute incremental approach” mode (MODE_IN=5).	1. Set the control signal for the “relative incremental approach” mode (MODE_IN=4).
2. Set the control signal for drive enable (DRV_EN=1).	
3. Set the function switch for “do not evaluate enable input” (EI_OFF=1) or wire up the enable input for the relevant channel.	
4. Enter the incremental dimension number (MODE_TYPE=254).	
5. Enter the incremental dimension for incremental dimension number 254 (TRG252_254).	
6. Set the trigger bit for writing the incremental dimension (TRG252_254_EN=1).	

Absolute Incremental Approach	Relative Incremental Approach
7. Set the control signal: <ul style="list-style-type: none"> • Linear axis: <ul style="list-style-type: none"> – START: The only possible direction is determined by the target and the current actual value. • Rotary axis <ul style="list-style-type: none"> – START: The target is approached along the shortest path. – DIR_P; Start in plus direction – DIR_M; Start in minus direction 	7. Set the control signal: <ul style="list-style-type: none"> • Linear axis: <ul style="list-style-type: none"> – DIR_P; Start in plus direction – DIR_M; Start in minus direction • Rotary axis <ul style="list-style-type: none"> – DIR_P; Start in plus direction – DIR_M; Start in minus direction
8. Call FC ABS_CTRL.	

Sequence of the “Incremental Approach” Mode with Incr. Dim. Number 255

Absolute Incremental Approach	Relative Incremental Approach
Incremental Dimension Number 255	
1. Set the control signal for the “absolute incremental approach” mode (MODE_IN=5).	1. Set the control signal for the “relative incremental approach” mode (MODE_IN=4).
2. Set the control signal for drive enable (DRV_EN=1). 3. Set the function switch for “do not evaluate enable input” (EI_OFF=1) or wire up the enable input for the relevant channel. 4. Enter the incremental dimension number (MODE_TYPE=255). 5. Enter the incremental dimension for incremental dimension number 255 (TRG255). 6. Enter the value of the switchover difference for incremental dimension number 255 (CHGDIF255). 7. Enter the value of the switch-off difference for incremental dimension number 255 (CUTDIF255). 8. Set the trigger bit for writing the incremental dimension, switch-off and switchover difference (TRG255_EN=1).	
9. Set the control signal: <ul style="list-style-type: none"> • Linear axis: <ul style="list-style-type: none"> – START: The only possible direction is determined by the target and the current actual value. • Rotary axis <ul style="list-style-type: none"> – START: The target is approached along the shortest path. – DIR_P; Start in plus direction – DIR_M; Start in minus direction 	9. Set the control signal: <ul style="list-style-type: none"> • Linear axis: <ul style="list-style-type: none"> – DIR_P; Start in plus direction – DIR_M; Start in minus direction • Rotary axis <ul style="list-style-type: none"> – DIR_P; Start in plus direction – DIR_M; Start in minus direction
10. Call FC ABS_CTRL.	

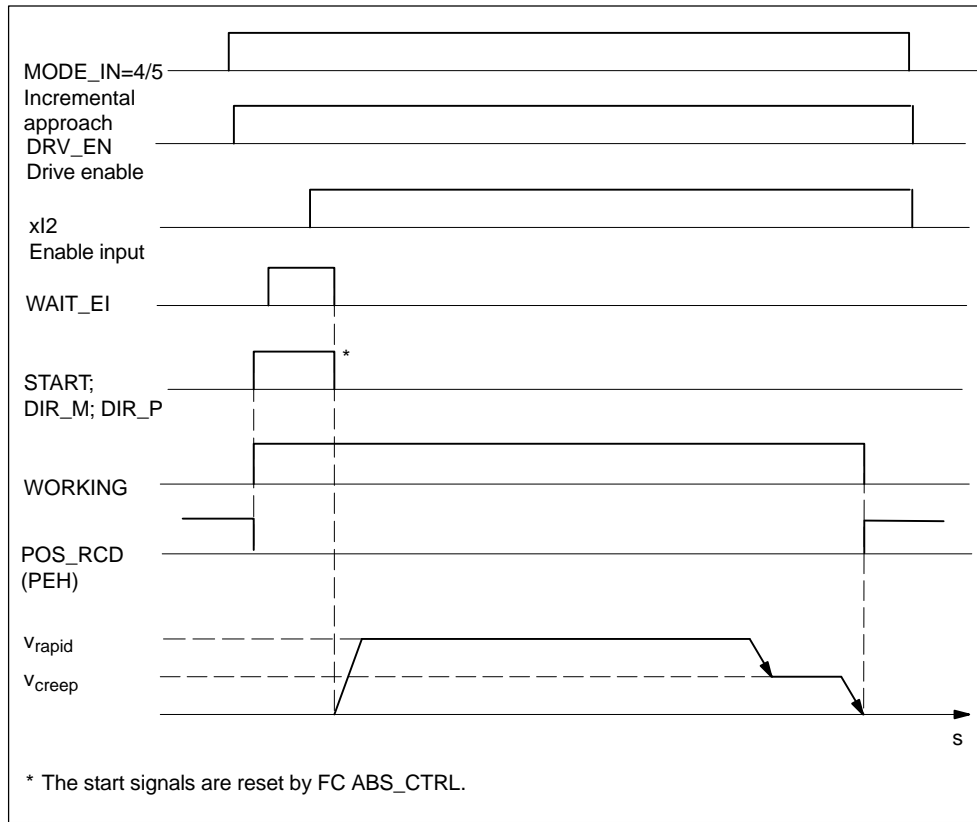

Figure 9-9 Example of the “Incremental Approach” Mode

Data Used in the Channel DB

Address	Name	Type	Initial Value	Comment
15.0	START	BOOL	FALSE	1 = start positioning
15.2	DIR_M	BOOL	FALSE	1 = direction minus
15.3	DIR_P	BOOL	FALSE	1 = direction plus
15.7	DRV_EN	BOOL	FALSE	1 = activate drive enable
16.0	MODE_IN	BYTE	B#16#0	4 = relative incremental approach 5 = absolute incremental approach
17.0	MODE_TYPE	BYTE	B#16#0	Incremental dimension number 1 – 100, 254 or 255
23.0	ST_ENBLD	BOOL	FALSE	1 = start enabled
23.1	WORKING	BOOL	FALSE	1 = positioning active
23.2	WAIT_EI	BOOL	FALSE	1 = axis waiting for ext. enable
25.7	POS_RCD	BOOL	FALSE	1 = position reached
34.2	EI_OFF	BOOL	FALSE	1 = do not evaluate enable input

Address	Name	Type	Initial Value	Comment
36.2	TRG252_254_EN	BOOL	FALSE	1 = write incremental dimension for incremental dimension number 254
36.3	TRG255_EN	BOOL	FALSE	1 = write incremental dimension for incremental dimension number 255
35.4	TRGL1WR_EN	BOOL	FALSE	1 = write incremental dimension table 1 (incremental dimension number 1 ... 50)
35.5	TRGL2WR_EN	BOOL	FALSE	1 = write incremental dimension table 2 (incremental dimension number 51 ... 100)
96.0	TRG252_254	DINT	L#0	Incremental dimension for incremental dimension number 254
100.0	TRG255	DINT	L#0	Incremental dimension for incremental dimension number 255
104.0	CHGDIF_255	DINT	L#0	Switchover difference for incremental dimension number 255
108.0	CUTDIF_255	DINT	L#0	Switch-off difference for incremental dimension number 255

Data Used in the Parameter DB

Address	Name	Type	Initial Value	Comment
100.0	CHGDIF_P	DINT	L#5000	Switchover difference plus
104.0	CHGDIF_M	DINT	L#5000	Switchover difference minus:
108.0	CUTDIF_P	DINT	L#2000	Switch-off difference plus
112.0	CUTDIF_M	DINT	L#2000	Switch-off difference minus
120.0	TRGL1.TRG[1]	DINT	L#0	Incremental dimension number 1
.	.	.	.	Incr. dim. table 1
316.0	TRGL1.TRG[50]	DINT	L#0	Incremental dimension number 50
320.0	TRGL2.TRG[51]	DINT	L#0	Incremental dimension number 51
.	.	.	.	Incr. dim. table 2
516.0	TRGL2.TRG[100]	DINT	L#0	Incremental dimension number 100

Remaining Distance

The remaining distance is the signed difference between the target (incremental dimension) and actual value.

On a rotary axis, the displayed remaining distance cannot be used.

Terminating an Incremental Approach

The “incremental approach” mode is terminated when the FM 351 receives a STOP signal (STOP=1).

After the approach has been terminated, a remaining distance still remains.

The remaining distance of a “relative incremental approach” can be traveled, when

- The operating mode is unchanged, and
- The incremental dimension number is unchanged,
- The direction is unchanged and
- The remaining distance is greater than the set switch-off difference.

You travel the remaining distance by starting the “relative incremental approach” unchanged.

Aborting an Incremental Approach

The “incremental approach” mode is aborted when the “drive enable” signal is cleared (DRV_EN=0).

Delete Remaining Distance

With the “delete remaining distance” job, you delete the current remaining distance.

If you start a different mode or start the mode in a different direction, you also delete the current remaining distance.

Data Used in the Channel DB

Address	Name	Type	Initial Value	Comment
35.2	DELDIST_EN	BOOL	FALSE	1 = delete remaining distance

9.5 Set Actual Value / Cancel Set Actual Value

Definition

With the “set actual value” job, you assign a new coordinate to the current encoder reading. The working range is projected to a different physical range on the axis.

You can calculate the offset of the working range as follows: $ACT_{new} - ACT_{current}$.

- ACT_{new} is the new specified value
- $ACT_{current}$ is the actual value at the time of execution

Requirements

- You have set the parameters for the axis.
- The axis must be synchronized.

Sequence of the Job

1. Enter the coordinate for the actual value (ACT_{new}) (AVAL).

- Linear axis:

You must select an actual value so that the software limit switch is still within the permitted travel range after the job has been called.

The value of the offset resulting from ($ACT_{new} - ACT_{current}$) must be less than or equal to the value of the permitted travel range (maximum 100 m or 1000 m).

- Rotary axis

The following rule must apply to the specified actual value:

$$0 \leq \text{actual value} < \text{end of rotary axis}$$

2. Set the corresponding trigger bit (AVAL_EN=1).

If the “set actual value” job is sent during a positioning operation, the job is held back until the operation is completed and is only executed the next time the block is called.

Data Used in the Channel DB

Address	Name	Type	Initial Value	Comment
35.7	AVAL_EN	BOOL	FALSE	1 = set actual value
84.0	AVAL	DINT	L#0	Coordinate for "set actual value"

Effects of the Job

Based on the example "set actual value" to 300 mm, you can see how the job projects the working range to a particular position of the axis. It produces the following effects:

- The actual position is set to the value of the actual value coordinate.
- The working range is offset on the axis.
- The individual points (for example software limit switch end) within the working range retain their original value, are located, however, at new positions.

Table 9-4 Offset of the Working Range on the Axis by "Set Actual Value"

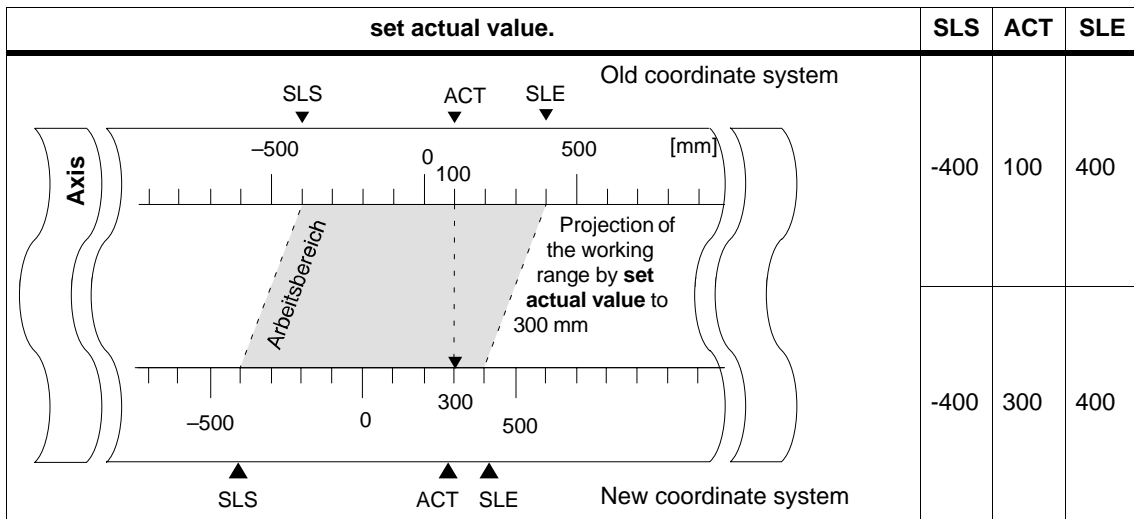

Canceling the Job (cancel set actual value)

With the "cancel set actual value" job, you reset all the working range offsets caused by "set actual value".

The sum of the working range offsets must not exceed the travel range for the job to be executed correctly.

Data Used in the Channel DB

Address	Name	Type	Initial Value	Comment
35.3	AVALREM_EN	BOOL	FALSE	1 = cancel set actual value

9.6 Set Reference Point

Definition

With the “set reference point” job, you can synchronize the axis. The job shifts the working range. All offsets resulting from set actual value are retained.

Requirement

- Positioning must be completed.
- You have set the parameters for the axis.

Sequence of the Job

1. Enter the value for the reference point coordinate (REFPT).

– Linear axis:

The reference-point coordinate must not be located outside the software limit switches. This also applies to the reference point coordinate in a shifted coordinate system.

– Rotary axis

The following rule applies to the reference point coordinate:

$$0 \leq \text{reference point coordinate} < \text{end of the rotary axis}$$

2. Set the corresponding trigger bit (REFPT_EN).

Data Used in the Channel DB

Address	Name	Type	Initial Value	Comment
25.0	SYNC	BOOL	FALSE	1 = axis is synchronized
35.6	REFPT_EN	BOOL	FALSE	1 = set reference point
92.0	REFPT	DINT	L#0	Reference point coordinate

Effects of the Job

Based on the example of “set reference point” to 400 mm, you can see how this job projects the working range to a specific physical position on the axis. It produces the following effects:

- The actual position is set to the value of the reference-point coordinate.
- The working range is offset on the axis.
- The individual points (for example software limit switch end) retain their original value but are located at new positions.
- The SYNC bit is set in the return signals.

Table 9-5 Shifting the Working Range on the Axis Using “Set Reference Point”

set reference point		SLS	ACT	SLE
		-400	200	400
		-400	400	400

Note on Absolute Encoders

This job is necessary for an absolute encoder adjustment (see section 8.6, page 8-19).

9.7 Loop Traverse

Definition

With “loop traverse”, you specify the direction in which a target will be approached with force contact. You can use the loop traverse when force contact between the motor and the axis can only be ensured in one direction.

A target which is approached against the specified direction is first overshoot. The FM 351 then reverses the direction and approaches the target in the specified direction.

Requirements

- You have set the parameters for the axis.
- The axis must be synchronized.
- In a loop traverse in a direction opposite to the direction to the target, the maximum target position is as follows:
 - in the plus travel direction

$$\text{target} \times \text{SLE} - \frac{1}{2} \text{target range} - \text{switch-off difference plus} - \text{switchover difference minus}$$
 - in the minus travel direction

$$\text{target} \pm \text{SLS} + \frac{1}{2} \text{target range} + \text{switch-off difference minus} + \text{switchover difference plus}$$
- A loop traverse is **not** executed if the target is approached in the direction of the loop traverse. In this case, an incremental approach without direction reversal is executed.
- The sequence of the “incremental approach” mode must be familiar (see Section 9.4, page 9-17).

Sequence of Loop Traverse

1. Set the control signal for the “absolute/relative incremental approach” mode (MODE_IN=4/5).
2. Set the control signal for drive enable (DRV_EN=1).
3. Set the function switch for “do not evaluate enable input” (EI_OFF=1) or wire up the enable input for the relevant channel.
4. Enter the incremental dimension number (MODE_TYPE=1...100, 254, 255).
5. Set the function switch (PLOOP_ON / MLOOP_ON=1).
6. Start the incremental approach

Data Used in the Channel DB

Address	Name	Type	Initial Value	Comment
15.0	START	BOOL	FALSE	1 = start positioning
15.2	DIR_M	BOOL	FALSE	1 = direction minus
15.3	DIR_P	BOOL	FALSE	1 = direction plus
15.7	DRV_EN	BOOL	FALSE	1 = activate drive enable
16.0	MODE_IN	BYTE	B#16#0	4/5= relative/absolute incremental approach
17.0	MODE_TYPE	BYTE	B#16#0	Incremental dimension number 1 – 100, 254 or 255
34.0	PLOOP_ON	BOOL	FALSE	1 = loop traverse in plus direction
34.1	MLOOP_ON	BOOL	FALSE	1 = loop traverse in minus direction
34.2	EI_OFF	BOOL	FALSE	1 = do not evaluate enable input

Fictitious Target

If you start positioning with a target that is located in the direction opposite to that set for the loop traverse, the FM 351 calculates a fictitious target for this target at which it reverses direction and then approaches the target in the correct direction.

This fictitious target **must** be located at a position corresponding to at least half the target range before the relevant software limit switch.

The distance between the fictitious target and the set target is calculated depending on the direction:

Table 9-6 Calculating the Location of the Fictitious Target for a Loop Traverse

Settings	Location of the Fictitious Target
Parameter settings: Loop + (force contact plus) and travel in minus direction.	<p>The fictitious target (target_f) has the value: $\text{Target}_f = \text{target} - \text{switch-off diff. minus} - \text{switchover diff. plus}$</p>
Parameter settings: Loop – (force contact minus) and travel in the plus direction.	<p>The fictitious target (target_f) has the value: $\text{Target}_f = \text{target} + \text{switch-off diff. plus} + \text{switchover diff. minus}$</p>

Example

Based on a positioning operation with a loop traverse minus to a maximum destination, we can illustrate the location of the fictitious target.

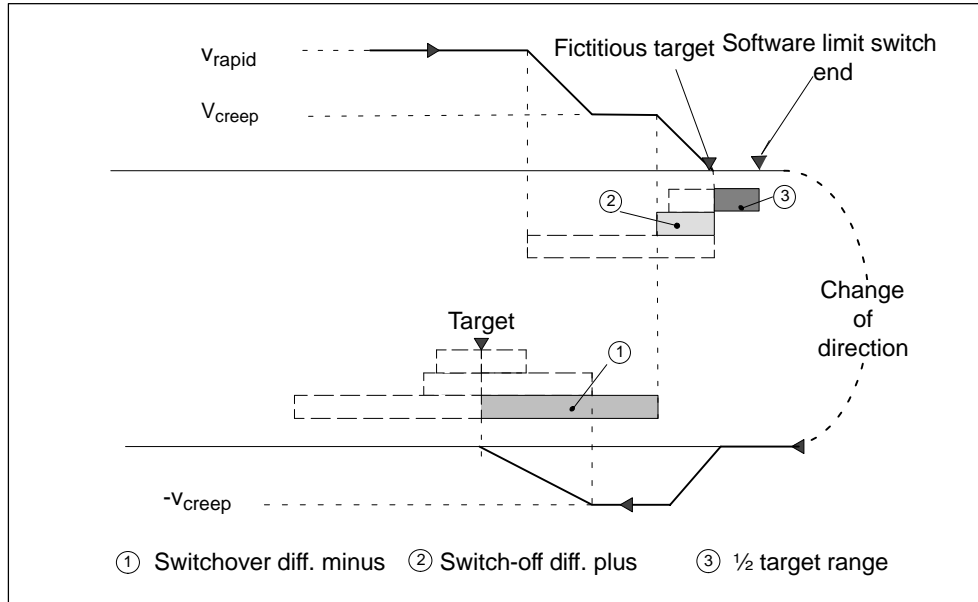

Figure 9-10 Loop Traverse Minus to a Maximum Target

9.8 Enable input

Definition

The enable input is an external input with which a positioning operation can be enabled as a result of an external event.

Evaluating the Enable Input (EI_OFF=0)

The relevant enable input (xI2) must be wired for the channel.

This allows you to prepare the start of a positioning operation.

You start the positioning operation independent of the execution of your user program by applying a “1” signal to the enable input.

Travel starts when you apply a “1” signal at the enable input and is stopped when you apply a “0” signal to the enable input.

Do Not Evaluate Enable Input (EI_OFF=1)

When you deactivate the evaluation of the enable input, an operating mode starts immediately after detection of the start signal. It is then not possible to prepare an operating mode and to start it at a defined later point in time.

Data Used in the Channel DB

Address	Name	Type	Initial Value	Comment
34.2	EI_OFF	BOOL	FALSE	1 = do not evaluate enable input

9.9 Read Position Data

Definition

With the “read position data” job, you can read the incremental dimension, remaining distance, and speed at the current time.

Sequence of the Job

1. Set the trigger bit in the channel DB (ACTSPD_EN=1).
2. The data are stored in the channel DB.

Data Used in the Channel DB

Address	Name	Type	Initial Value	Comment
37.1	ACTSPD_EN	BOOL	FALSE	1 = read position data
112.0	ACTSPD	DINT	L#0	Current speed
116.0	DIST_TO_GO	DINT	L#0	Residual distance
120.0	ACT_TRG	DINT	L#0	Current incremental dimension

9.10 Read Encoder Data

Definition

With the “read encoder data” job, you read the current data of the encoder and the value of the absolute encoder adjustment.

Requirements

You can read out the value for the absolute encoder adjustment after executing the “set reference point” job (see Section 8.6, page 8-19).

Sequence of the Job

1. Set the trigger bit in the channel DB (ENCVAL_EN=1).
2. The data are stored in the channel DB.

Data Used in the Channel DB

Address	Name	Type	Initial Value	Comment
37.2	ENCVAL_EN	BOOL	FALSE	1 = read encoder values
124.0	ENCVAL	DINT	L#0	Encoder actual value (internal representation)
128.0	ZEROVAL	DINT	L#0	Last zero marker value (internal representation)
132.0	ENC_ADJ	DINT	L#0	Absolute encoder adjustment

9.11 Return Signals for Positioning

Definition

With the “return signals for positioning”, you are informed of the current status of the positioning operation.

Sequence

The data are stored in the channel DB whenever FC ABS_CTRL is called.

Data Used in the Channel DB

Address	Name	Type	Initial Value	Comment
23.0	ST_ENBLD	BOOL	FALSE	1 = start enabled
23.1	WORKING	BOOL	FALSE	1 = positioning active
23.2	WAIT_EI	BOOL	FALSE	1 = axis waiting for ext. enable
23.4	SPEED_OUT	BOOL	FALSE	0 = creep speed 1 = rapid speed
23.5	ZSPEED	BOOL	FALSE	1 = axis is in the stationary range
23.6	CUTOFF	BOOL	FALSE	1 = axis is located in the switch-off range
23.7	CHGOVER	BOOL	FALSE	1 = axis is located in the switchover range
24.0	MODE_OUT	BYTE	B#16#0	Active mode
25.2	GO_M	BOOL	FALSE	1 = axis traveling in minus direction
25.3	GO_P	BOOL	FALSE	1 = axis traveling in plus direction
25.7	POS_RCD	BOOL	FALSE	1 = position reached
26.0	ACT_POS	DINT	L#0	Actual position (actual position of the axis)

9.12 Return Signals for Diagnostics

Definition

The “return signals for diagnostics” job informs you of diagnostic events that have occurred.

Sequence

1. When the module enters a new event in the diagnostic buffer, it sets the DIAG bit in all channels. Whenever an error occurs belonging to any of the error classes listed in Appendix C, an entry is made in the diagnostic buffer. If you delete the diagnostic buffer, the DIAG bit is also set.
2. If it is not possible to call a mode or to control an active mode or if an error occurs attempting either of these actions, the module sets an operator error (OT_ERR). The cause of the error is entered in the diagnostic buffer. As long as the operator error is set, you can neither start a new mode nor continue the stopped mode. You acknowledge an operator error with OT_ERR_A=1.
3. If the module recognizes a write job with incorrect data, it sets the DATA_ERR bit. The cause of the error is entered in the diagnostic buffer.
4. The return signals are stored in the channel DB.
5. Once the diagnostic buffer has been read, the module resets the DIAG bit to 0 in all channels.

Data Used in the Channel DB

Address	Name	Type	Initial Value	Comment
22.2	DIAG	BOOL	FALSE	1 = diagnostic buffer modified
22.3	OT_ERR	BOOL	FALSE	1 = operator error
22.4	DATA_ERR	BOOL	FALSE	1 = data error

Encoders

10

Chapter Overview

Section	Topic	Page
10.1	Incremental Encoders	10-2
10.2	Absolute Encoders	10-4

10.1 Incremental Encoders

Connectable Incremental Encoders

Incremental encoders with two pulses electrically offset by 90° with or without zero markers are supported:

- Encoders with asymmetric output signals with 24 V level
 - Cut-off frequency = 50 kHz:
 - max. 100 m line length.
- Geber mit symmetrischen Ausgangssignalen mit 5V-Differenzschnittstelle nach RS 422
 - Cut-off frequency = 400 kHz
 - At 5 V supply voltage: max. 32 m line length.
 - At 24 V supply voltage: max. 100 m line length.

Note

If the encoder (5 V) does not output a zero marker signal and you have activated the wire-break monitoring, you must connect the zero marker inputs N and \bar{N} externally so that these inputs have a different level (for example, N at 5V, \bar{N} at chassis).

Signal Shapes

Figure 10-1 illustrates the signal shapes from encoders with asymmetric and symmetric output signals.

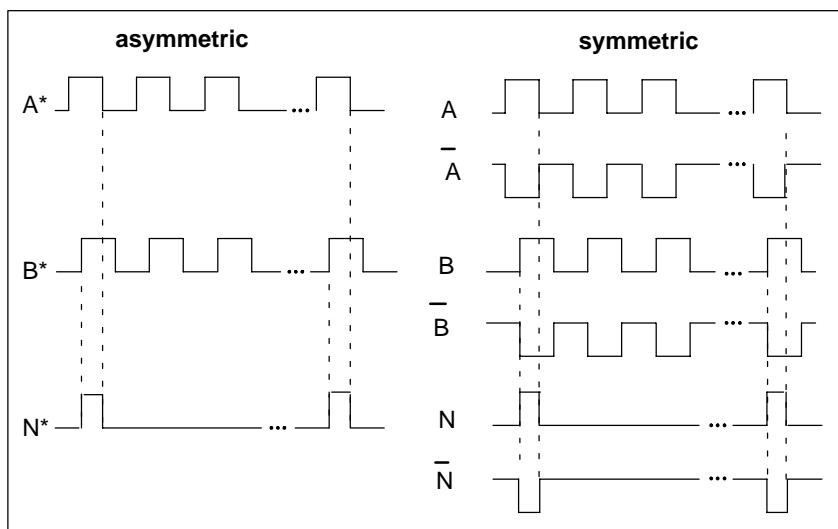

Figure 10-1 Signal Waveforms from Incremental Encoders

Signal Evaluation

Increments

An increment identifies a signal period of the two encoder signals A and B. This value is listed in the specifications of an encoder and/or on its type label.

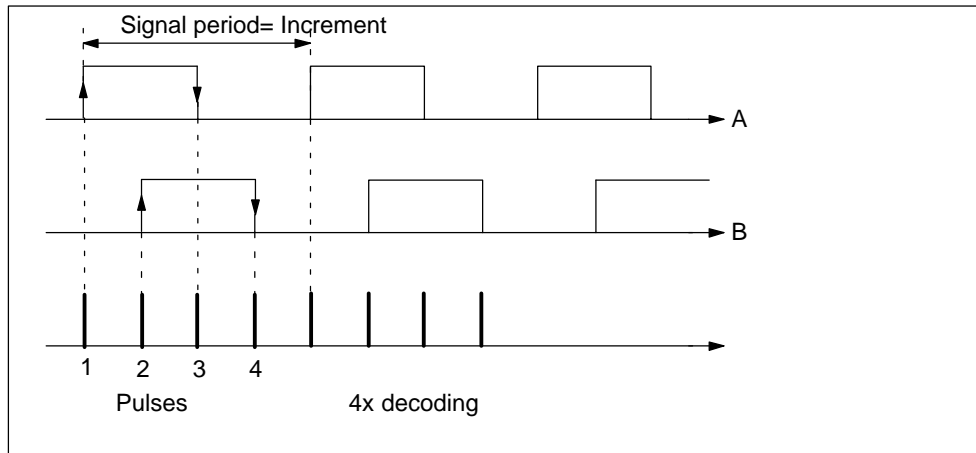

Figure 10-2 Increments and Pulses

Pulses

The FM 351 evaluates all 4 edges of the signals A and B (see figure) in each increment (4x decoding).

1 increment (from encoder) = 1 pulse (FM evaluation)

Reaction Times

With incremental encoders connected, the FM 351 has the following reaction times:

Reaction time = switching time of the connecting switching elements

Note

You can compensate the minimum reaction time by appropriate parameter settings for the switchover and switch-off differences.

Unsharpness

Unsharpness affects the positioning accuracy. With incremental encoders the unsharpness is negligible.

10.2 Absolute Encoders

Single-turn and Multiturn Encoders

Absolute encoders are grouped as follows:

- Single-Turn Encoders
Single-turn encoders cover the total measuring range in one encoder revolution.
- Multiturn Encoders
Multiturn encoders cover the measuring range in a number of encoder revolutions.

Connectable Absolute Encoders

Absolute encoders with a serial interface are supported. Position information is transferred synchronously using the SSI protocol (**s**ynchronous **s**erial **i**nterface). The FM 351 supports only GRAY code. Due to the arrangement of the data bits in the transferred frames, the data formats 25-bit (“fir tree”), and 13-bit (“half fir tree”) are used.

Encoder Type	Frame Length
Single-turn	13 bits
Single-turn	25 bits
Multiturn	25 bits

Data Transfer

The baud rate for the data transfer depends on the cord length (see Appendix A, Technical Specifications).

Pulse Evaluation with Absolute Encoders

1 Inkrement (Gebervorgabe) = 1 Impuls (FM–Auswertung)

Reaction Times

With absolute encoders, the FM 351 has the following reaction times:

Minimum reaction time = frame run time + switching time of the connected switching elements
Maximum reaction time = 2 × frame run time + monoflop time + switching time of the connected switching elements
With programmable absolute encoders:
Maximum reaction time = frame run time + monoflop time + switching time of the connected switching elements +1/max. step train frequency

Monoflop Time

The monoflop time is 64 µs.

Encoders with values higher than the limit shown here are not permitted.

Frame Run Times

The frame run times depend on the baud rate:

Baud Rate	Frame Transfer Time (13-bit)	Frame Transfer Time (25-bit)
0,188 MHz	75 µs	139 µs
0,375 MHz	38 µs	70 µs
0,750 MHz	19 µs	35 µs
1,500 MHz	10 µs	18 µs

Example of Reaction Times

This example shows how to calculate the minimum and maximum reaction time. The encoder in the example is not programmable.

- Hardware switching time: approx. 150 µs
- Frame transfer time: 18 µs at 1,5 MHz baud rate (25-bit frame)
- Monoflop time: 64 µs

Minimum reaction time = 18 µs + 150 µs = 168 µs

Maximum reaction time = 2 × 18 µs + 64 µs + 150 µs = 250 µs

Note

You can compensate the minimum reaction time by appropriate parameter settings for the switchover and switch-off differences.

Unsharpness

Unsharpness is the difference between the maximum and minimum reaction time.
With an Absolute encoder it is as follows:

Unsharpness = frame transfer time + monoflop time

With programmable absolute encoders:

Unsharpness = frame run time + monoflop time + $1/\text{max. step train frequency}$

Diagnostics

11

Chapter Overview

Section	Topic	Page
11.1	Options for Displaying and Evaluating Errors	11-2
11.2	Types of Error	11-2
11.3	Meaning of the Error LEDs	11-3
11.4	Displaying Errors on an OP	11-4
11.5	Error Evaluation in the User Program	11-5
11.6	Diagnostic Buffer of the Module	11-10
11.7	Diagnostic Interrupts	11-11

11.1 Options for Displaying and Evaluating Errors

You can obtain information on errors in the following ways:

- Observing the error LEDs on the module.
The meaning of the error LEDs is explained in Section 11.3 (page 11-3).
- Connect your programming device with the CPU and open the error evaluation dialog of the configuration software. The current (error) state of the module is displayed along with the error class, error number and a plain language explanation. When necessary, you can update the display by clicking the "Update" button.
The causes of the displayed error messages and possible remedies are explained in the error list in Appendix C.5 (page C-15).
- Write a detailed error evaluation routine in your user program (see Section 11.4, page 11-4) or a reaction to a diagnostic interrupt (see Section 11.4 and 11.7).
- To display errors on an OP: Read out the diagnostic buffer of the module cyclically in your user program (see Figure 11-2). Evaluate the diagnostic DB on the OP. The meaning of the error class and error number is explained in the error list in Appendix C.5 (page C-15).

Deleting the Diagnostic Buffer

To give you a better chronological overview of the error messages, the FM 351 allows you to delete the diagnostic buffer completely. This is, however, only possible when a positioning operation has been completed and when you have set parameters for the channel.

11.2 Types of Error

11.2.1 Synchronous Errors

These errors occur at the same time as a job or the start of a positioning operation. Synchronous errors are operator errors (error class 2), data errors (error class 4), machine data errors (error class 5), incremental dimension table errors (error class 6) (refer to the error list in Appendix C.5, page C-15).

11.2.2 Asynchronous Errors

These errors occur during operation as a result of external events. These errors trigger a diagnostic interrupt. Asynchronous errors include operating errors (error class 1) and diagnostic errors (error class 128) (refer to the error list in Appendix C.5, page C-15).

11.3 Meaning of the Error LEDs

The status and error LEDs indicate various error states.

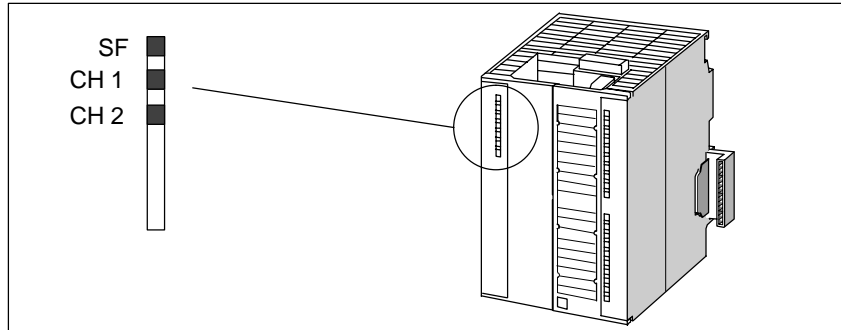

Figure 11-1 Status and Error Indicators of the FM 351

LED	Meaning	Explanation
SF (red) LED – ON	Group error	This LED indicates an error on the FM 351. Diagnostic interrupt (internal or external (channel) error) To eliminate the error, refer to the error list in the Appendix C.5 (page C-15).
CH 1 (red) CH 2 (red)	Channel error 1 Channel error 2	These LEDs indicate channel errors on channel 1 or channel 2. <ul style="list-style-type: none"> Encoder wire break Absolute encoder errors Incremental encoder missing pulses Operating errors Parameter assignment error with parameters from the SDB.

11.4 Displaying Errors on an OP

Figure 11-2 shows the structure of a user program as illustrated in Figure 6-2 with extra functions for reading out the diagnostic buffer for display on an OP. FC DIAG stores the diagnostic buffer in a DB that can be displayed by the OP.

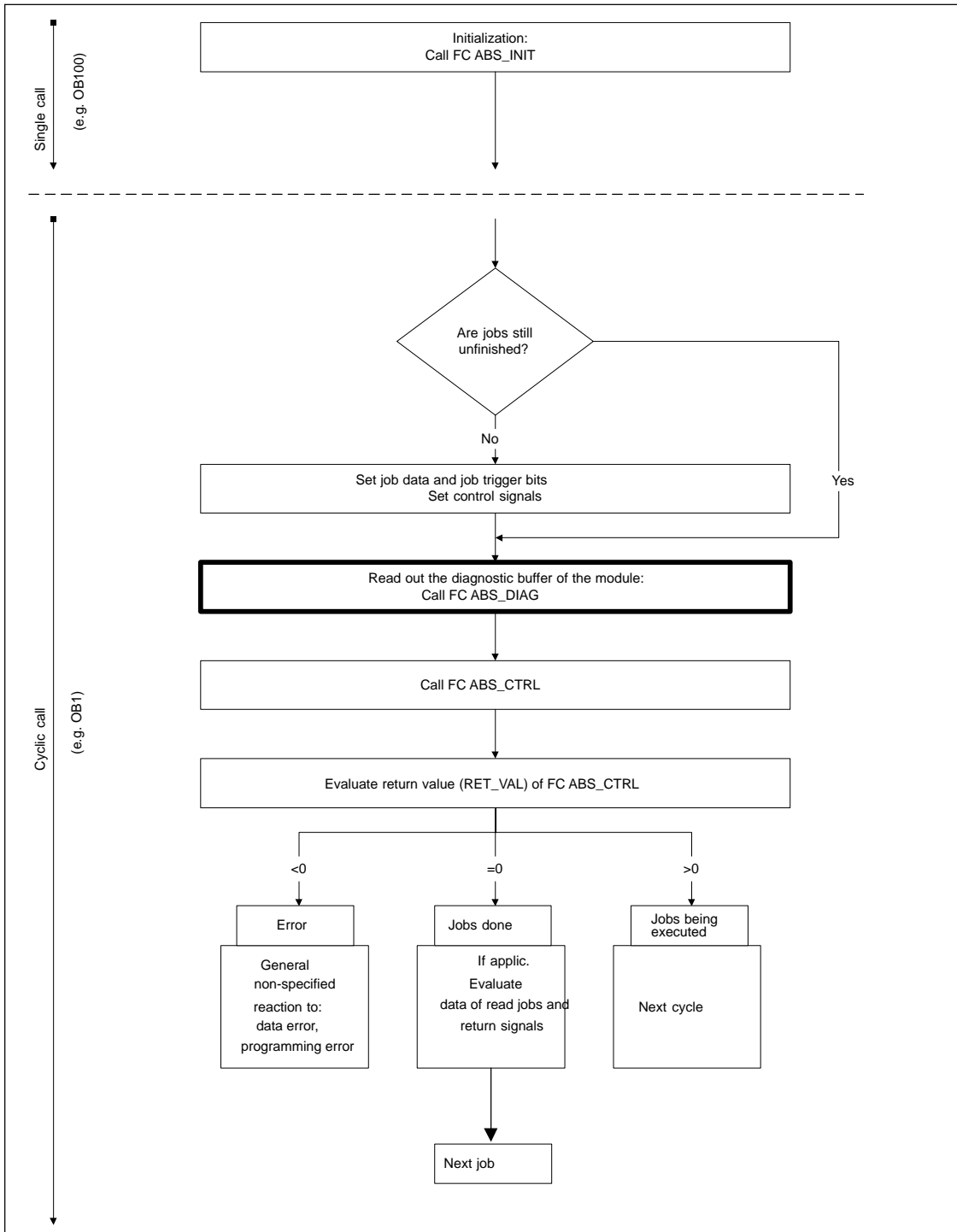

Figure 11-2 Program Structure with Diagnostic Display for an OP

11.5 Error Evaluation in the User Program

In your user program, you can plan specific reactions to errors. The following data are available for this purpose:

- The return values (RET_VAL) of the linked standard FCs:
This value is refreshed each time the block is called.
RET_VAL = -1 is a group indicator for a synchronous error in a job or in the communication of the module.
- Each job has an error bit (_ERR) as a group indicator for an error in the job or in one of its predecessors in a chain of jobs:
The error bit is set for a write job and for the subsequent jobs if a data error was indicated by the module or if a communication error occurred.
In read jobs, the error bit is set for the job affected if a communication error occurred.
The error bits are set again by FC ABS_CTRL after a job has been executed. They should be reset however by the user program to allow error evaluation.
- The return signal DATA_ERR is a group indicator for an error detected by the module in a write job. The signal is updated with the next write job.
- The return signal OT_ERR (operator error) is used as a group indicator for an error detected by the module when a travel operation is started. The error must be acknowledged after it has been eliminated by setting OT_ERR_A=1.
- The return signal DIAG is set when the content of the diagnostic buffer changes. This signal can come later than the signals DATA_ERR and OT_ERR.
- The communication error JOB_ERR contains an error code for a communication problem between the FC and module (refer to the list of JOB_ERR messages in Appendix C.4). The value is updated after a job has been executed and stored by FC ABS_CTRL in the channel DB and by FC ABS_DIAG in the diagnostic DB.
- FC ABS_DIAG for reading out the diagnostic buffer of the module. Here, you can find out the causes of errors for synchronous and asynchronous events.
- Diagnostic interrupts for fast reaction to events in the diagnostic interrupt OB (OB82).

Figure 11-3 shows a possible program structure with which you can react to the return signals "Data Error" (DATA_ERR), "Operator Error" (OT_ERR) and the error bits of the jobs (_ERR).

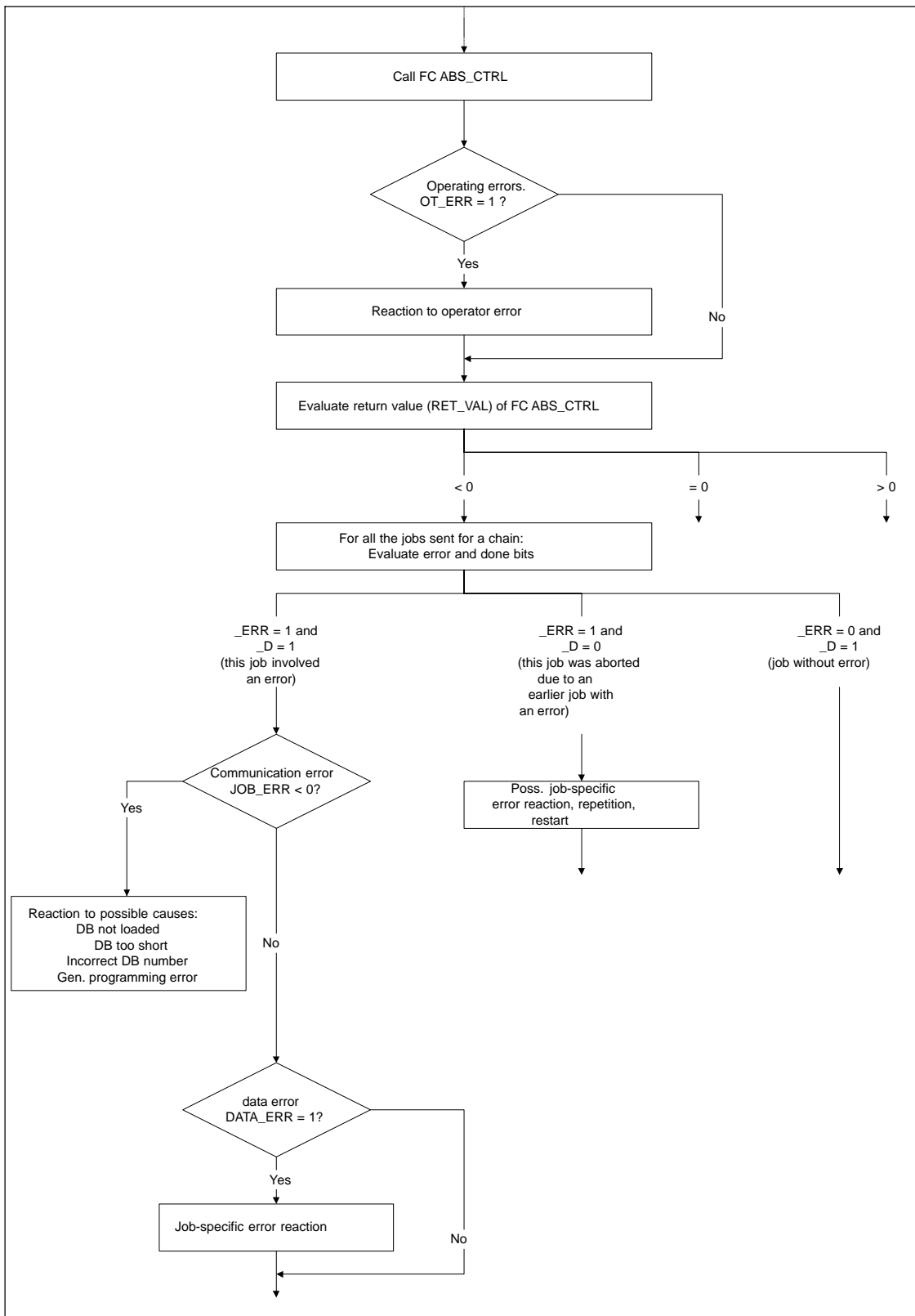

Figure 11-3 User Program with Evaluation of the Error Bits of the Jobs

Figure 11-4 shows a possible program structure with which you can evaluate all errors based on the entries in the diagnostic DB. This allows you to react in the program when one or more new errors are entered in the diagnostic buffer of the module. Several possible programmed reactions are shown in detail in Figures 11-5 to 11-8.

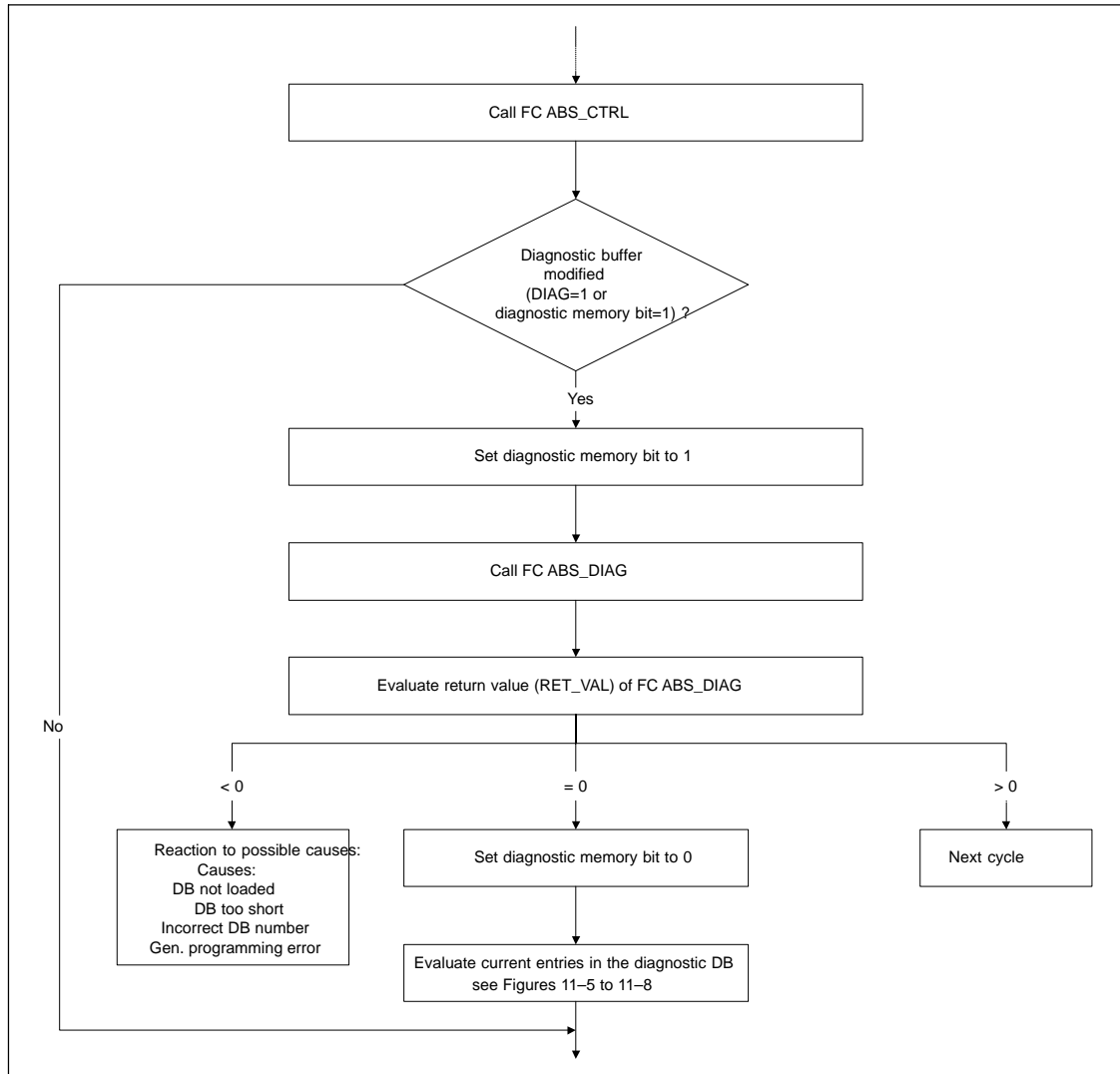

Figure 11-4 User Program with Complete Evaluation using the Diagnostic DB

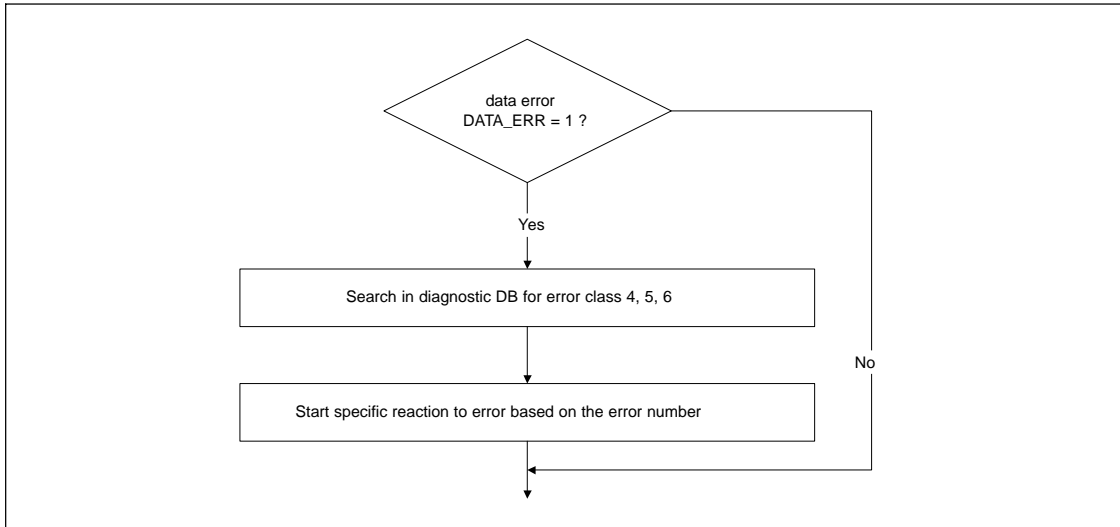

Figure 11-5 Possible Evaluation of a Data Error

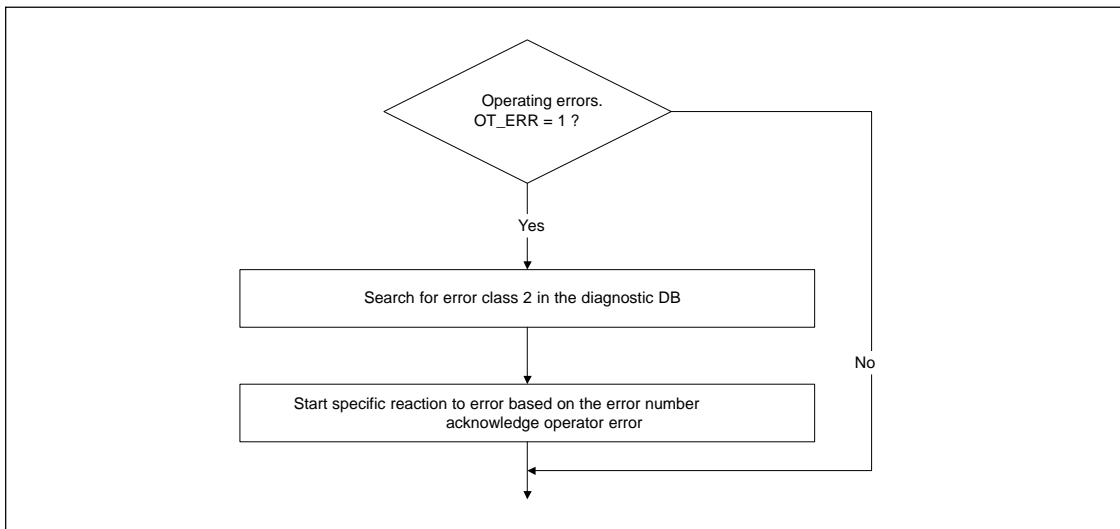

Figure 11-6 Possible Evaluation of an Operator Error

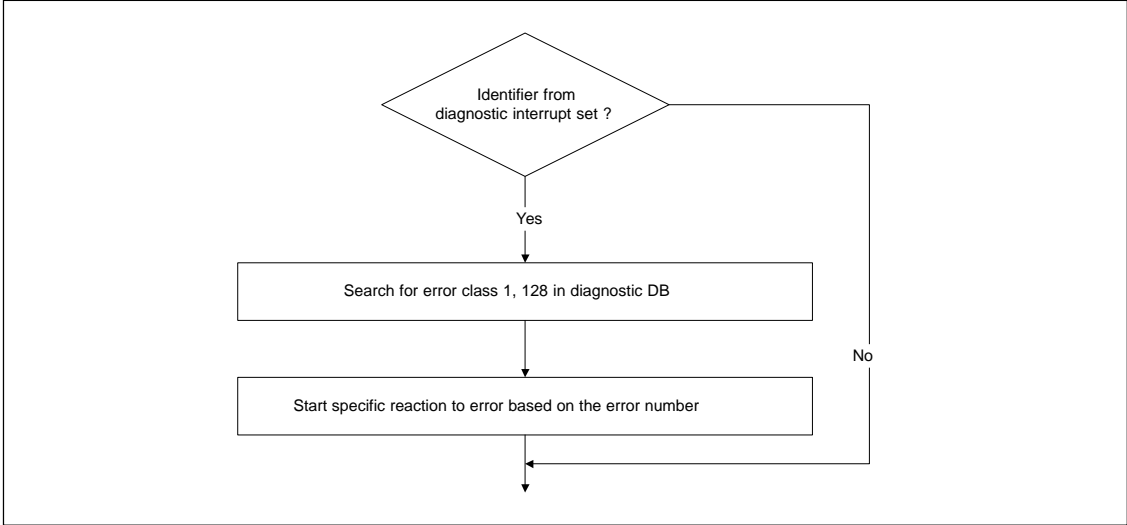

Figure 11-7 Possible Evaluation of a Diagnostic Interrupt

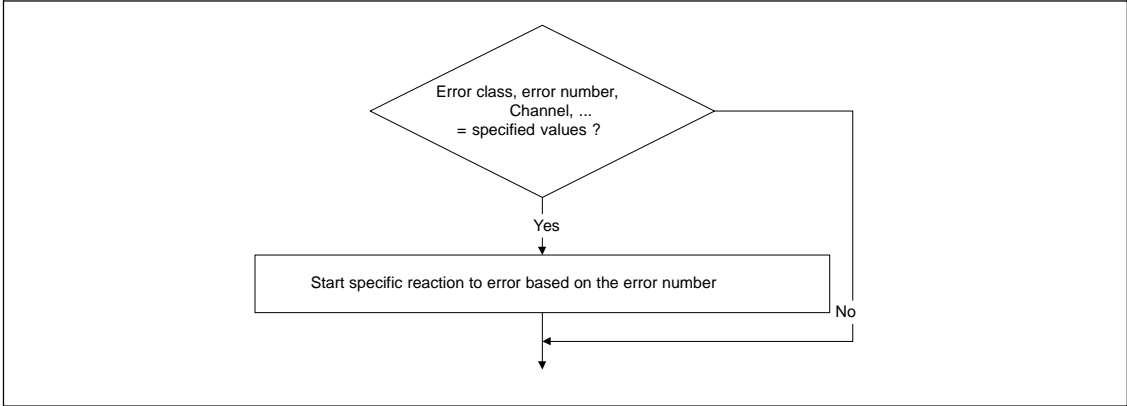

Figure 11-8 Possible Evaluation of Specifically Selected Error

11.6 Diagnostic Buffer of the Module

The diagnostic buffer of the module contains a maximum of 9 diagnostic entries and is organized as a ring buffer.

A diagnostic event is written to the buffer when a message (error) “entering state” is detected. This can be a synchronous error (data error, operator error) or an asynchronous error (operating error, diagnostic error). One problem can also cause several entries as follow-on errors. Messages for events “leaving state” do not cause entries in the diagnostic buffer.

The following is specified for each diagnostic event:

- Status (always entering state)
- Internal error
- External error
- Error class
- Error number
- Channel number
- Incremental dimension number (for incremental dimension errors)

If a diagnostic event is written to the diagnostic buffer, the return signal DIAG=1 is set in all channels being used.

The entire diagnostic buffer can be transferred to a data block (diagnostic DB) using FC ABS_DIAG or displayed in the error evaluation dialog of the configuration software. If the diagnostic buffer is read, the module sets the return signal DIAG=0.

Note

If the diagnostic buffer is read simultaneously by FC ABS_DIAG and the error evaluation dialog, it is possible that a newly entered diagnostic event is not detected by the program.

11.7 Diagnostic Interrupts

Interrupt Handling

The FM 351 can trigger diagnostic interrupts. You service these interrupts in an interrupt OB. If an interrupt is triggered and the corresponding OB is not loaded, the CPU changes to STOP (refer to the manual *Programming with STEP 7*).

You enable the servicing of diagnostic interrupts as follows:

1. Select the module in HW Config
2. Using the menu command **Edit > Object Properties > Basic Parameters** , enable diagnostic interrupts.
3. Save and compile the hardware configuration.
4. Download the hardware configuration to the CPU.

Overview of the Diagnostic Interrupts

The following events and errors trigger a diagnostic interrupt:

- Operating errors
- Incorrect machine data (when parameters assigned with SDB)
- Diagnostic errors

These errors are explained in detail in Appendix C.5, page C-15 onwards.

Reaction of the FM 351 to an Error with a Diagnostic Interrupt

- Positioning is aborted.
- The synchronization is deleted with the following diagnostic interrupts:
 - Front connector not plugged in, no external auxiliary supply for the encoder,
 - A zero marker error was detected, cable fault (5 V encoder signals)
 - The travel range was exceeded (indicated by an operating error)
 - Set actual value cannot be executed (indicated by an operating error).
- With one exception, the control signals START, DIR_P and DIR_M are no longer processed
Exception:
If an operating error occurs, jogging in the direction of the working range is possible.
- Function switches and jobs continue to be processed.

The FM 351 detects an error (“entering state”)

A diagnostic interrupt is “entering state” if at least one error is pending. If only some of the errors are eliminated, the remaining pending errors are signaled again as “entering state”.

Sequence:

1. The FM 351 detects one or more errors and initiates a diagnostic interrupt. The “SF” LED is lit and the LEDs “CH1” / “CH2” LEDs are lit depending on the error. The error is entered in the diagnostic buffer.
2. The CPU operating system calls OB 82.
3. You can evaluate the start information of OB82.
4. With the OB82_MOD_ADDR parameter, you can see which module triggered the interrupt.
5. You can obtain further information by calling FC ABS_DIAG.

The FM 351 detects that an error state is cleared (“leaving state”)

A diagnostic interrupt is then only “leaving state” if the last error on the module has been rectified.

Sequence:

1. The FM 351 detects that all errors have been rectified and initiates a diagnostic interrupt. The “SF” LED is no longer lit. The diagnostic buffer is not modified.
2. The CPU operating system calls OB 82.
3. With the OB82_MOD_ADDR parameter, you can see which module triggered the interrupt.
4. Evaluate the OB82_MDL_DEFECT bit.

If this bit is “0”, then there are no errors on the module. Your evaluation can stop here.

Diagnostic Interrupts Depending on the CPU Status

- In the CPU STOP state the diagnostic interrupts from the FM 351 are disabled.
- If not all of the pending errors are eliminated while the CPU is in the STOP mode, the FM 351 signals the errors that have not yet been eliminated as “entering state” again when the CPU changes to RUN.
- If all errors have been rectified in the CPU STOP state, then the error-free FM 351 state is **not** signaled with a diagnostic interrupt after the transition to the RUN state.

Evaluation of a Diagnostic Interrupt in the User Program

The FM 351 sets the following entries in the local data of the diagnostic interrupt OB (OB82). The errors are also entered in the diagnostic buffer (error class 128, for the meaning and possible remedies, refer to Appendix C.5):

Address	Name	Type	Comment
0.0	OB82_EV_CLASS	BYTE	Event class and IDs: B#16#38: Event leaving state B#16#39: Event entering state
1.0	OB82_FLT_ID	BYTE	Error code (B#16#42)
2.0	OB82_PRIORITY	BYTE	Priority class: B#16#1A in the RUN mode B#16#1C in the STARTUP mode
3.0	OB82_OB_NUMBR	BYTE	OB number (82)
4.0	OB82_RESERVED_1	BYTE	Reserved
5.0	OB82_IO_FLAG	BYTE	Input module: B#16#54
6.0	OB82_MDL_ADDR	INT	Logical base address of the module on which the error occurred
8.0	OB82_MDL_DEFECT	BOOL	Module fault
8.1	OB82_INT_FAULT	BOOL	Internal error
8.2	OB82_EXT_FAULT	BOOL	External error
8.3	OB82_PNT_INFO	BOOL	Channel error
8.4	OB82_EXT_VOLTAGE	BOOL	External auxiliary voltage missing
...	Not used		
10.3	OB82_WTCH_DOG_FLT	BOOL	Watchdog monitoring has responded
...	Not used		
12.0	OB82_DATE_TIME	DATE_AND_TIME	Date and time at which the OB was called

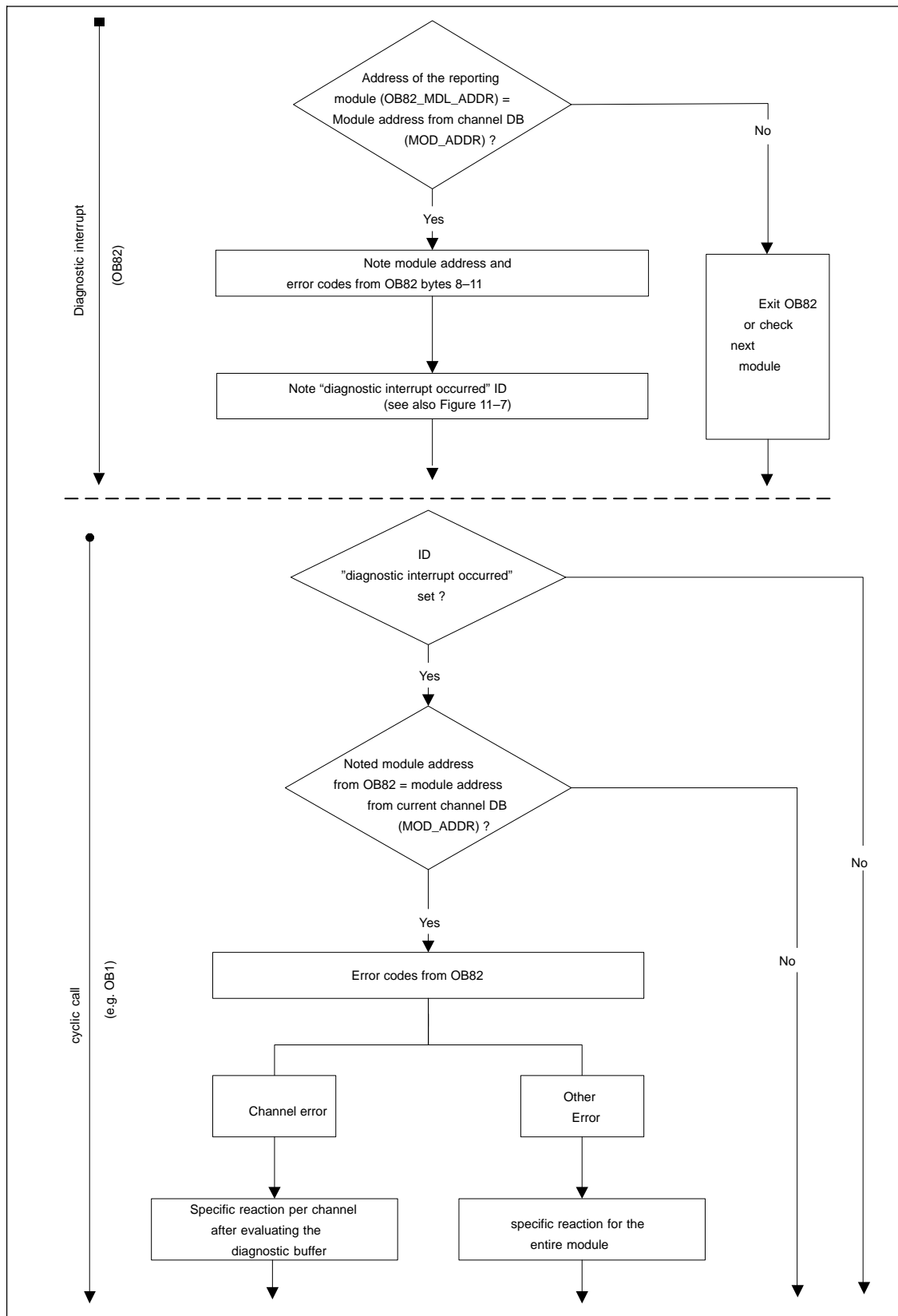

Figure 11-9 Possible Evaluation of a Diagnostic Interrupt

Samples

12

Chapter Overview

Section	Topic	Page
12.1	Introduction	12-2
12.2	Requirements	12-2
12.3	Preparing the Samples	12-3
12.4	Code of the Samples	12-3
12.5	Testing a Sample	12-4
12.6	Adapting a Sample	12-4
12.7	Sample Program 1 "GettingStarted"	12-5
12.8	Sample Program 2 "Commission"	12-7
12.9	Sample Program 3 "AllFunctions"	12-9
12.10	Sample Program 4 "OneChannel"	12-11
12.11	Sample Program 5 "DiagnosticAndInterrupt"	12-14
12.12	Sample Program 6 "MultiChannels"	12-16

12.1 Introduction

When you install the FM 351/FM 451 configuration package, a sample project is also installed that illustrates several typical applications based on a number of selected functions.

The English sample project is in the following folder:

...\STEP7\EXAMPLES\zEn18_01

This contains several S7 programs of varying complexity and with different aims. The programs include comprehensive comments.

12.2 Requirements

The following requirements must be met:

- You have created and wired up an S7 station consisting of a power supply module, a CPU, and an FM 351 module, (version ≥ 3) or FM 451 (version ≥ 2). Earlier versions of the module may deviate from the behavior described.
- You have correctly installed STEP 7 and the configuration package for the FMx51 on your programming device/PC. The description of how to handle the programs is based on STEP 7 V5.0. If you use a different version of STEP 7, the procedures may differ slightly.
- The programming device is connected to the CPU.

You can operate an FM 351 or an FM 451 with these samples.

12.3 Preparing the Samples

To be able work through the samples online, make the following preparations:

1. Open the sample project **zEn18_01_FMx51___Prog** in the folder **...\\STEP7\\EXAMPLES** using the SIMATIC Manager (use the detailed display so that you can see the symbolic names) and copy it to your project folder assigning a suitable name (**File > Save As**).
2. Insert a station in your project to match your hardware configuration.
3. Select a sample program and copy the program to the offline CPU.
4. Configure the hardware completely in HW Config.
5. Set the parameters for the FM 351 or FM 451 based on “Getting Started”. Export the parameters you have adapted to your system to the parameter DBs of all samples except for the sample “Getting Started” using **File > Export**.
6. Select the FM 351 or FM 451 in the hardware configuration and display the object properties (**Edit > Object Properties**).
In the “Mod Adr...” dialog, enter the current module address in all offline channel DBs (CHAN_1, CHAN_2) and diagnostic DBs (DIAG) that exist in the sample program. The module address must not be entered in your parameter DBs (PARADB_1, PARADB_2) because these would then be incorrectly overwritten. Open the dialog separately for each block.
You can also enter the module address with the LAD/STL/FBD editor in the MOD_ADDR block parameter.
7. Save the hardware configuration and download it to the CPU.
8. Select a sample program and download its block folder to the online CPU.
9. If you want to try out the next sample, go to step 8.

12.4 Code of the Samples

The samples are written in STL. You can view them directly in the LAD/STL/FBD editor.

Select the view with “Symbolic Representation”, “Symbol Selection” and “Comment”. If you have sufficient space on the monitor, you can also display the “Symbol Information”.

12.5 Testing a Sample

When you have made all the necessary entries for the sample, download the complete block folder to the CPU.

The sample programs include variable tables (VATs) with which you can view and modify the data blocks online (in other words in the RUN-P mode on the CPU). In the variable table, select the views "Symbol" and "Symbol Comment". Open a variable table, link it with the configured CPU and monitor the variables cyclically. The displayed variables are then continuously updated. By transferring the control values, you can modify the values in the online data blocks.

All the samples require that the machine data were entered and saved in the parameter dialogs. This allows you to execute the samples one after the other.

If "continuous reading" from the FM 351 is programmed in your application (for example, position values), this may impede the updating of the parameter dialogs when using an S7-300 CPU.

12.6 Adapting a Sample

You can use the code of the samples directly as user program.

The code of the samples is neither optimized nor designed for all eventualities. Error evaluation is not programmed in detail in the sample programs to avoid the programs becoming unwieldy.

The "AllFunctions" sample program can be used as a template to form the basis of your user program, which you tailor to your needs by modifying and deleting functions.

The samples are prepared for channel 1 ("MultiChannels" for channels 1 and 2). If necessary, adapt the channel number with the LAD/STL/FBD editor.

12.7 Sample Program 1 “GettingStarted”

Aim:

With this sample, you start up your positioning module which has parameter settings based on “Getting Started”.

The sample extends the program shown in the “Linking in the User Program” chapter of “Getting Started” by adding error evaluation.

Requirements:

You have set the parameters for your positioning module as described in “Getting Started”.

The address of your module is entered correctly in the channel DB in the parameter MOD_ADDR and the channel number in the parameter CH_NO.

Startup:

In the startup OB (OB100) you call FC ABS_INIT that resets all the control and return signals and the job management in the channel DB.

Cyclic Operation:

Open the variable table (VAT_CTRL_1), establish the connection to the configured CPU and monitor the variables. Transfer the prepared control values. Activate “CHAN_1”.DRV_EN: The drive is now enabled (“CHAN_1”.ST_ENBLD=1). If the drive is not enabled, check your enable inputs.



Caution

With the next two steps, you start the drive.

You can stop the drive again in one of the following ways:

- Set the control value for the direction to 0 again and activate it
 - Set the control value for the drive enable to 0 again and activate it
 - Change the CPU to the STOP mode
-

Set DIR_P=1 to travel in the plus direction in the selected mode “Jogging”. If you set DIR_P=0, the drive will be correctly deactivated.

Error Evaluation:

Create a data error by setting the reference point coordinate "CHAN_1".REFPT in VAT_CTRL_1 outside the working range or the end of the rotary axis. Then activate the "set reference point" job with "CHAN_1".REFPT_EN=1. The CPU changes to STOP. (In a sample, this is the simplest method of indicating an error. You can, of course, program a different error evaluation.)

Open HW Config and double-click on the FM 351 or FM 451. The parameter assignment software is started. Display the cause of the error in the dialog by selecting **Test > Error Evaluation**.

The status values in VAT_CTRL_1 still indicate the status before the CPU changed to STOP. Update the status values to view the error and done bits of the jobs.

To eliminate the error, follow the steps outlined below:

1. Enter a permitted value in the control value.
2. Switch the CPU to STOP.
3. Switch the CPU to RUN-P.
4. Activate the control values. If you activate the control values before the CPU restarts, they are reset by the initialization in OB100 and therefore have no effect.

12.8 Sample Program 2 “Commission”

Aim:

In this sample, you put the positioning module into operation without the parameter assignment dialogs. You control and monitor using variable tables (VATs).

Requirements:

You have set the parameters for your positioning module as described in “Getting Started”.

The address of your module is entered correctly in the channel DB in the parameter MOD_ADDR and the channel number in the parameter CH_NO.

The address of your module is correctly entered in the diagnostic DB in the MOD_ADDR parameter.

The supplied channel DB already contains the DB number (30) of the corresponding parameter DB for the machine data in the PARADBNO parameter.

The machine data of your system are stored in the data block PARADB_1.

Startup:

In the startup OB (OB100), call FC ABS_INIT to initialize the channel DB. You then set the trigger bits for all jobs that you require after the module starts.

Cyclic Operation:

Open the variable table (VAT_CTRL_1), establish the connection to the configured CPU and monitor the variables.

Transfer the prepared control values. The “jogging” mode is selected and the required enable signals are set. With DIR_P=1, the drive turns. The actual value must change. To stop the drive, set STOP to “1” and transfer the control values. Activate and transfer the control value “CHAN_1”.REFPT_EN (set reference point). The return signal “CHAN_1”.SYNC =1 means that the channel is synchronized.

In VAT_DIAG, you can see the most important entries of the diagnostic buffer of the module. The meaning of the error classes and error numbers is described in the manual in Appendix C.5, pageC-15.

Error Evaluation:

Attempt to create further errors:

- Specify a reference point coordinate that is higher than the working range or end of the rotary axis.
- Turn off the external power supply.
- Delete PARADB_1 on the online CPU and attempt to write machine data. (In the sample, the error evaluation is programmed so that the CPU changes to STOP. When you update VAT_CTRL_1 again, the error code for this error is displayed in "CHAN_1".JOB_ERR. The meaning of the error codes is described in the manual in Appendix C.4, pageC-13.)

12.9 Sample Program 3 “AllFunctions”

Aim:

In this sample you will find all the functions of the FM 351/451:

- Modes
- Function switches
- Write jobs
- Read jobs

You can use the sample program as a template to form the basis of your user program, which you tailor to your needs by modifying and deleting functions. The data you need to adapt to your application are marked ***. Some functions are available only for the FM 451.

Reactions to external events and the error evaluation are system-specific and are therefore not included in the sample.

Requirements:

You have set the parameters for your positioning module as described in “Getting Started”.

The address of your module is entered correctly in the channel DB in the parameter MOD_ADDR and the channel number in the parameter CH_NO.

The supplied channel DB already contains the DB number (30) of the corresponding parameter DB for the machine data in the PARADBNO parameter.

The machine data of your system are stored in the data block PARADB_1.

Startup:

In the startup OB (OB100), call FC ABS_INIT to initialize the channel DB. You then set the trigger bits for all jobs that you require after the module starts.

Operation:

The CPU is in the STOP mode. Open the variable table USER_VAT and enter the job number required for your user program in the control values. The job numbers are explained in the code of the sample.

The correct combination of the user data "USER_DB".CTRL_SIG, "USER_DB".FUNC_SW, "USER_DB".WR_JOBS, "USER_DB".RD_JOBS and "USER_DB".RETVAL_CTRL is necessary.

For more detailed information, refer to chapter 9.

Establish the connection to the configured CPU and transfer and activate the control values.

Start the CPU (STOP > RUN-P). Monitor the return signals and actual values.

You can repeat the execution of the steps in the sequence by changing the CPU from STOP to RUN again. This method is, of course, not suitable for continuous operation. The aim in the example, is to reinitialize the module each time.

12.10 Sample Program 4 “OneChannel”

Aim:

In this sample, you control a drive with the user program. The user program starts up the module following a CPU warm restart. Afterwards, it executes a series of steps that reacts to events.

Using the variable tables, you set the events, monitor the reactions of the module and evaluate the diagnostic buffer.

In this somewhat more complex sample, you can get to know the following options available with the blocks:

- Specifying several jobs at the same time
- Mixing write and read jobs
- Reading using a permanent job without waiting for the end of the job
- Evaluating the return signals of the block
- Evaluating the return signals of an individual job
- Resetting the done and error bits for individual or for all jobs
- Central ABS_CTRL call at the end of the user program

Requirements:

You have set the parameters for your positioning module as described in “Getting Started”.

The address of your module is entered correctly in the channel DB in the parameter MOD_ADDR and the channel number in the parameter CH_NO.

The supplied channel DB already contains the DB number (30) of the corresponding parameter DB for the machine data in the PARADBNO parameter.

The machine data of your system are stored in the data block PARADB_1.

Startup:

In the startup OB (OB100) you set the startup flag (Step 0) for the user program in the corresponding instance DB (USER_DB).

Operation:

The CPU is in the STOP mode. Open the variable table USER_VAT, adapt the incremental dimensions ("USER_DB".TRG_INC_1, "USER_DB".TRG_INC_2), the switch over difference ("USER_DB".CHGDIF) and the switch-off difference ("USER_DB".CUTDIF) to your system and transferee the control values.

Start the CPU (STOP > RUN-P). Watch the step number of the sequence ("USER_DB".STEPNO), the return signals, and the actual values. After initialization, a "relative incremental approach" is executed. The drives moves in a negative direction to its first position ("USER_DB".TRG_INC_1).

The program then waits in step 6 for an external trigger ("USER_DB".START_INC_2), to trigger the next incremental approach in the plus direction. When the position is reached, the sequence of steps is located at its final value (-2). The incremental approach with incremental dimension number 255 allows the transfer of the switch over and switch-off difference. This allows you to test the final target approach.

You can repeat execution of the sequence of steps by triggering a new start (STOP > RUN-P) on the CPU. This method is, of course, not suitable for continuous operation. The aim in the example, is to reinitialize the module each time.

Error Evaluation:

If an error occurs during execution, the sequence of steps is stopped. The value -1 is entered as the step number.

Try to create errors that are entered in the "USER_DB".ERR bit as group errors by the central error evaluation.

- In USER_VAT, activate the prepared control value for incremental dimension number 1 ("USER_DB".TRG_INC_1), that is higher than the software limit switch.
The sequence of steps is stopped, -1 is displayed as the step number. Check the error using the error evaluation dialog.
- In USER_VAT, activate further control values for incremental dimension number 1 ("USER_DB".TRG_INC_1) one after the other, incremental dimension number 255 ("USER_DB".TRG_INC_2), or the switchover difference ("USER_DB".CHGDIF) and switch-off difference ("USER_DB".CUTDIF). Check the error in the same way as for incremental dimension 1.

User program FB1 (USER_PROG):

The user program accesses the data in the module-specific data blocks (USER_DB) with the form <blockname>.<symbolic name>. This means that the user program can operate exactly one channel. The DB number specified in the user program call is simply passed on so that FC_ABS_CTRL is supplied with values. With this type of programming, you can access data in the data block using symbolic names. Indirect addressing of more than one channel is part of the sample program 6 "MultiChannels".

The user program executes a sequence of steps made up as follows:

Step 0: The positioning module is initialized. The jobs with the corresponding data are set that will be executed when the module is started up.

Step 1: The program waits for the jobs set in step 0 to be processed.

Step 2: The values set for the incremental dimension "USER_DB".TRG_INC_1 is entered in the incremental dimension table. The incremental dimension table is then written to the module. The control signals for the first incremental approach are sent at the same time. FC_ABS_CTRL make sure that the order of execution from step 2 in correct.

Step 3: The program waits for the execution of the set write job.

Step 4: The program waits for the "PEH" return signal and the updated position values from the first incremental approach.

Step 5: The values set for the second incremental approach, switchover difference, and switch-off difference are entered in the channel DB. The second incremental approach with incremental dimension number 255 is then started with "USER_DB".START_INC_2 .

Step 6: The program waits for the execution of the set jobs.

Step 7: If an error occurs in the execution, the sequence of steps is stopped.

12.11 Sample Program 5 “DiagnosticAndInterrupt”

Aim:

This sample contains a user program with the same task as in Sample Program 4 “OneChannel”. In this sample, we will show you how to evaluate a diagnostic interrupt for certain modules and how to process this in the user program to produce a general module error.

Requirements:

You have set the parameters for your positioning module as described in “Getting Started”.

The address of your module is entered correctly in the channel DB in the parameter MOD_ADDR and the channel number in the parameter CH_NO.

The address of your module is correctly entered in the diagnostic DB in the MOD_ADDR parameter.

The supplied channel DB already contains the DB number (30) of the corresponding parameter DB for the machine data in the PARADBNO parameter.

The machine data of your system are stored in the data block PARADB_1.

In the hardware configuration, enable the diagnostic interrupt for this module with **Edit > Object Properties > Basic Parameters > Select Interrupt > Diagnostics**. Compile the hardware configuration and download it to the CPU.

Startup:

In the startup OB (OB100), the startup flag (step 0) for the user program is set in the instance DB.

Operation:

As in Sample Program 4 “OneChannel”.

Error Evaluation:

If an error occurs during execution, the sequence of steps is stopped. The value -1 is entered as the step number. You will find the latest entry of the diagnostic buffer in USER_VAT. You can find out the cause of the error using the error class and error number (appendix C.5, page C-15).

Try to create errors that are entered in the "USER_DB".ERR bit as group errors by the central error evaluation.

- In USER_VAT, activate the prepared control value for incremental dimension number 1 ("USER_DB".TRG_INC_1), that is higher than the software limit switch.
The sequence of steps is stopped, -1 is displayed as the step number. Check the errors in the error evaluation dialog or in the diagnostic data in USER_VAT.
- In USER_VAT, activate further control values for incremental dimension number 1 ("USER_DB".TRG_INC_1) one after the other, incremental dimension number 255 ("USER_DB".TRG_INC_2), or the switchover difference ("USER_DB".CHGDIF) and switch-off difference ("USER_DB".CUTDIF). Check the error in the same way as for incremental dimension 1.
- Produce a diagnostic interrupt by disconnecting the power supply for the module or by removing the front connector. The diagnostic error "USER_DB".ERR_MOD and group error "USER_DB".ERR become 1 and the step number becomes -1 .

User Program (FB PROG):

The task is the same as in Sample Program 4 "OneChannel".

In this sample, no special measures have been taken for restarting after eliminating the error.

Diagnostic interrupt (OB82)

Depending on the address of the module that triggered the interrupt (OB82_MDL_ADDR), the error ID in the corresponding instance DB (USER_DB) of the user program is entered in the diagnostic interrupt. There is a reaction in the cyclic user program.

12.12 Sample Program 6 “MultiChannels”

Aim:

This example contains the same user program as sample program 4 “OneChannel”, however, it controls 2 channels of the module. The same copy of the user program is used for both channels. Naturally, each channel has its own set of data blocks.

Requirements:

You have set parameters for channel 1 as described in “Getting Started”. Copy channel 1 to channel 2 with **Edit > Copy Channel**.

Where necessary, adapt the parameters for channel 2. Save the hardware configuration and download it to the CPU.

The address of your module is entered correctly in the channel DB in the parameter MOD_ADDR and the channel number in the parameter CH_NO.

The address of your module is correctly entered in the diagnostic DB in the MOD_ADDR parameter.

The supplied channel DBs already contain the DB number (30 or 31) of the corresponding parameter DB for the machine data in the PARADBNO parameter.

The data blocks PARADB_1 and PARADB_2 each containing machine data for 1 channel of your system.

In the hardware configuration, enable the diagnostic interrupt for this module with **Edit > Object Properties > Basic Parameters > Select Interrupt > Diagnostics**.

Compile the hardware configuration and download it to the CPU.

A variable table is prepared for each channel.

Startup:

In the startup OB (OB100), you set the startup ID (step 0) for the user program in both instance DBs (USER_DB_1, USER_DB_2).

Operation:

The CPU is in the STOP mode. Open USER_VAT_1 and USER_VAT_2 and transfer their control values.

Start the CPU (STOP > RUN-P). You can see how the actual positions of both channels change.

Error Evaluation:

As in Sample Program 5 “DiagnosticAndInterrupt”, but separately for each channel.

User Program (FB PROG):

The aim and sequence of the user program are as in Sample Program 5 “DiagnosticAndInterrupt” and Sample Program 4 “OneChannel”.

The user program is designed for the operation of more than one channel since it accesses the module-specific data blocks indirectly (channel DBs, diagnostic DB, and parameter DBs). The DB numbers specified in the call are not only passed on to supply FC ABS_CTRL and FC ABS_DIAG but are also used in the user program. With this type of programming, you cannot use symbolic names for the data in the data blocks.

Diagnostic interrupt (OB82)

Depending on the address of the channel that triggered the interrupt (OB82_MDL_ADDR), the error ID in the corresponding instance DB of the user program is entered in the diagnostic interrupt.

Technical Specifications

A

General Technical Specifications

The following Technical Specifications are described in the reference manual *S7-300/M7-300 Programmable Controllers, Module Data*.

- Electromagnetic compatibility
- Transport and storage conditions
- Mechanical and climatic ambient conditions
- Details on insulation tests, class and level of protection.
- Approvals and Standards



Warning

Injury to persons and damage to property may occur.

In areas subject to explosion hazards, persons may be injured and property damaged if you disconnect lines to S7-300 during operation.

Electrically disconnect the S7-300 before separating plug connections in areas subject to explosion hazards.



Warning

WARNING - DO NOT DISCONNECT WHILE CIRCUIT IS LIVE
UNLESS LOCATION IS KNOWN TO BE NON-HAZARDOUS

CE Mark

Our products meet the requirements of the EU directive 89/336/EEC "Electromagnetic Compatibility" and the harmonized European standards (EN) listed in the directive.



In compliance with the above mentioned EU directive, Article 10, the conformity declarations are available to the relevant authorities at the following address:

Siemens Aktiengesellschaft
Bereich Automatisierungstechnik
A&D AS E4
Postfach 1963
D-92209 Amberg, Germany

Area of Application

SIMATIC products are designed for use in an industrial environment.

Area of Application	Requirements	
	Emitted interference	Immunity
Industry	EN 50081-2 : 1993	EN 50082-2 : 1995

Adherence to Installation Instructions

SIMATIC products meet the requirements if you follow the installation instructions described in manuals during both installation and operation.

Technical Specifications

Dimensions and weight	
Dimensions W × H × D (mm)	80 × 125 × 120
Weight	Approx. 535 g
Current, voltage and power	
Current consumption (from the backplane bus)	max. 200 mA
Power dissipation	Typ. 7.9 W
Auxiliary power supply for the encoders	Auxiliary supply: 24 V DC (X1, terminal 1) (permitted range: 20.4 to 28.8V)
Encoder supply	<ul style="list-style-type: none"> • Horizontal installation S7-300, 20° C: <ul style="list-style-type: none"> – 5.2 V/500 mA (for both channels) – 24 V/800 mA (for both channels) • Horizontal installation S7-300, 60° C: <ul style="list-style-type: none"> – 5.2 V/500 mA (for both channels) – 24 V/600 mA (for both channels) • Vertical installation S7-300 S7-300, 40° C: <ul style="list-style-type: none"> – 5.2 V/500 mA (for both channels) – 24 V/600 mA (for both channels) • Current consumption from 1L+ (without load): max. 100 mA (X1, terminal 1) • Encoder supply 24 V, unregulated <ul style="list-style-type: none"> – L+ –2V (X2/X3, terminal 5) – Short-circuit protection: yes, thermic • Encoder power supply 5.2V (X2/X3, terminal 6) Short-circuit protection: yes, electroic • Permitted potential difference between input (ground) and central ground connection of the CPU: DC 1V
Auxiliary power supply for the load current	Auxiliary supply: 24 V DC (X1, terminal 19) (permitted range: 20.4 to 28.8V)
Supply of digital inputs and outputs	<ul style="list-style-type: none"> • Current consumption from 2L+ (without load): max. 50 mA (X1, terminal 19) • Permitted potential difference between input ground connection 1M (X1, terminal 2) <ul style="list-style-type: none"> – and the central grounding point (shield): AC 60V; DC 75V – Insulation tested with 500 V DC • Permitted potential difference between input ground connection 2M (X1, terminal 20) <ul style="list-style-type: none"> – and the central grounding point (shield): AC 60V; DC 75V – Insulation tested with 500 V DC
Load voltage reverse polarity protection	No

Encoder inputs	
Distance measurement	<ul style="list-style-type: none"> • Incremental • Absolute
Signal voltages	<ul style="list-style-type: none"> • Symmetrical inputs: 5 V to RS 422 • Asymmetrical inputs: 24 V/ typ. 4 mA
Input frequency and cord length for asymmetrical incremental encoder with 5 V supply	Max. 400 KHz for 32 m shielded cord length
Input frequency and cord length for asymmetrical incremental encoder with 24 V supply	Max. 400 KHz for 100 m shielded cord length
Input frequency and cord length for asymmetrical incremental encoder with 24 V supply	<ul style="list-style-type: none"> • Max. 50 KHz for 25 m shielded cable length • Max. 25 KHz for 100 m shielded cord length
Data transfer rate and cord length for absolute encoders	<ul style="list-style-type: none"> • Max. 188 KHz for 200 m shielded cord length • Max. 375 KHz for 100 m shielded cord length • Max. 750 KHz for 40 m shielded cord length • Max. 1,5 MHz for 12 m shielded cord length
Monitoring possible for absolute encoders	No
Input signals	<ul style="list-style-type: none"> • Incremental: 2 pulse trains, 90° offset, 1 zero pulse • Absolute: Absolute value
Digital inputs	
Number of digital inputs	8
Number of simultaneously controllable digital inputs	8
Electrical isolation	yes, optocoupler
Status indication	yes, green LED per digital input
Input voltage	<ul style="list-style-type: none"> • 0 signal: -3 ... 5V • 1 signal: 11 V to 30 V
Input current	<ul style="list-style-type: none"> • 0 signal: ≤ 2 mA (closed-circuit current) • 1 signal: 6 mA
Input delay (1I0, 1I1, 1I2 and 2I0, 2I1, 2I2)	<ul style="list-style-type: none"> • 0 → 1 signal: Typ. 3 ms • 1 → 0 signal: Typ. 3 ms
Input delay (1I3 and 2I3)	<ul style="list-style-type: none"> • 0 → 1 signal: Typ. 300 μs • 1 → 0 signal: Typ. 300 μs
Connection of a 2-wire BERO	Possible
Cable length unshielded (1I0, 1I1, 1I2 and 2I0, 2I1, 2I2)	100 m
Cable length shielded (1I0, 1I1, 1I2 and 2I0, 2I1, 2I2)	max. 600 m
Cable length shielded (1I3 and 2I3)	max. 100 m
Insulation test	VDE 0160
Digital outputs	

Digital outputs	
Number of outputs	8
Electrical isolation	yes, optocoupler
Status indication	yes, green LED per digital output
Output current	<ul style="list-style-type: none"> • 0 signal: 0.5 mA • 1 signal: 0.5 A (Permissible range: 5...600 mA) • Lamp load: 5 W
Output delay for output current 0.5 A	<ul style="list-style-type: none"> • 0 → 1 signal: max. 300 μs • 1 → 0 signal: max. 300 μs
Signal level for 1 signal	L+ -0.8V
Control of a digital input	Yes
Control of a counter input	no, due to 50 μs missing pulse
Short circuit protection	yes, thermally clocked threshold 1 A
Limit on induct. cut-off voltage	Typ. L+: -48V
Switching frequency	<ul style="list-style-type: none"> • Resistive load: Max. 100 Hz • Inductive load: Max. 0.5 Hz
Total current of digital outputs with S7-300 horizontal installation	Simultaneity factor 75 %: at 20° C and 60° C: 3 A
Total current of digital outputs with S7-300 vertical installation	Simultaneity factor 75 %: at 40° C: 3 A
Unshielded cord length	Max. 100 m
Shielded cord length	max. 600 m
Insulation test	VDE 0160

Note

When the 24 V power supply is turned on using a mechanical contact, the FM 351 applies a pulse to the outputs. Within the permitted output current range, the pulse may be 50 μs. You must take this into account when you use the FM 351 in conjunction with fast counters.

B

Connection Diagrams

Overview

The following table describes encoders that you can connect to the FM 351. The connection diagrams for these encoders are described in this chapter.

Section	Connection Diagram for	Connecting Cable	Remark	Page
B.1	Incremental encoder Siemens 6FX 2001-2□□□□	$4 \times 2 \times 0.25 + 2 \times 1 \text{ mm}^2$	Incremental encoder: $U_p=5V$, RS-422	B-2
B.2	Incremental encoder Siemens 6FX 2001-2□□□□	$4 \times 2 \times 0.5 \text{ mm}^2$	Incremental encoder: $U_p=24 \text{ V}$, RS-422	B-3
B.3	Incremental encoder Siemens 6FX 2001-4□□□□	$4 \times 2 \times 0.5 \text{ mm}^2$	Incremental encoder: $U_p=24V$, HTL	B-4
B.4	Absolute encoder Siemens 6FX 2001-5□□□□	$4 \times 2 \times 0.5 \text{ mm}^2$	Absolute encoder: $U_p=24V$, SSI	B-5

B.1 Connection Diagram for Incremental Encoder Siemens 6FX 2001-2 (U_p=5V; RS 422)

Connection Diagram

The following illustration shows the connecting diagram for the incremental encoder Siemens 6FX 2001-2 (U_p=5 V; RS422):

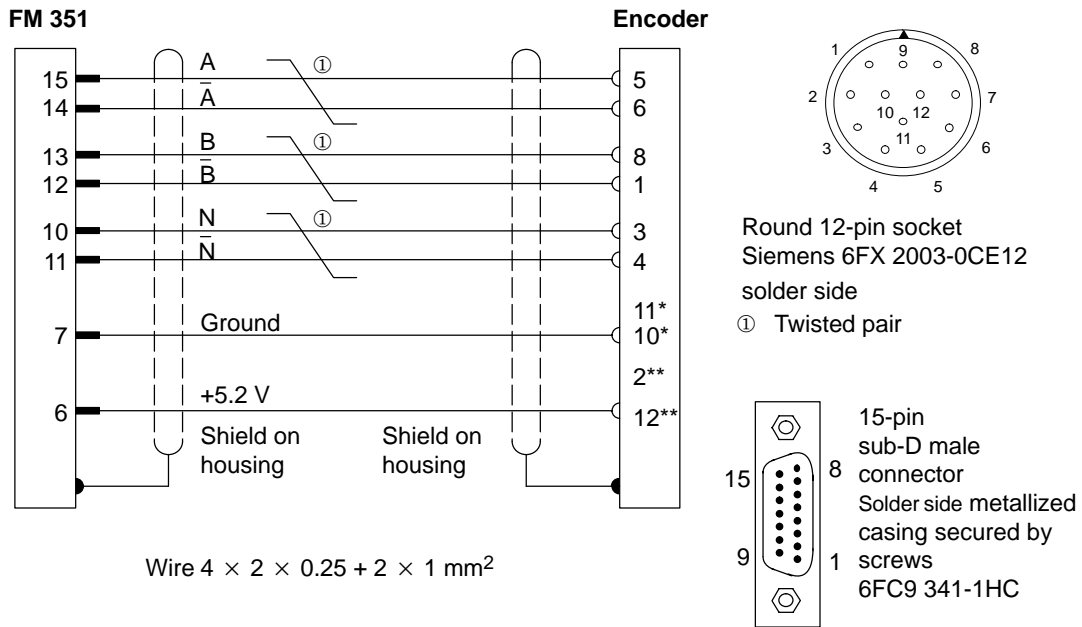

* Pins 10 and 11 are jumpered internally.

** Pins 2 and 12 are jumpered internally.

B.2 Connection Diagram for Incremental Encoder Siemens 6FX 2001-2 (Up=24V; RS 422)

Connection Diagram

The following illustration shows the connecting diagram for the incremental encoder Siemens 6FX 2001-2 (Up=24 V; RS 422):

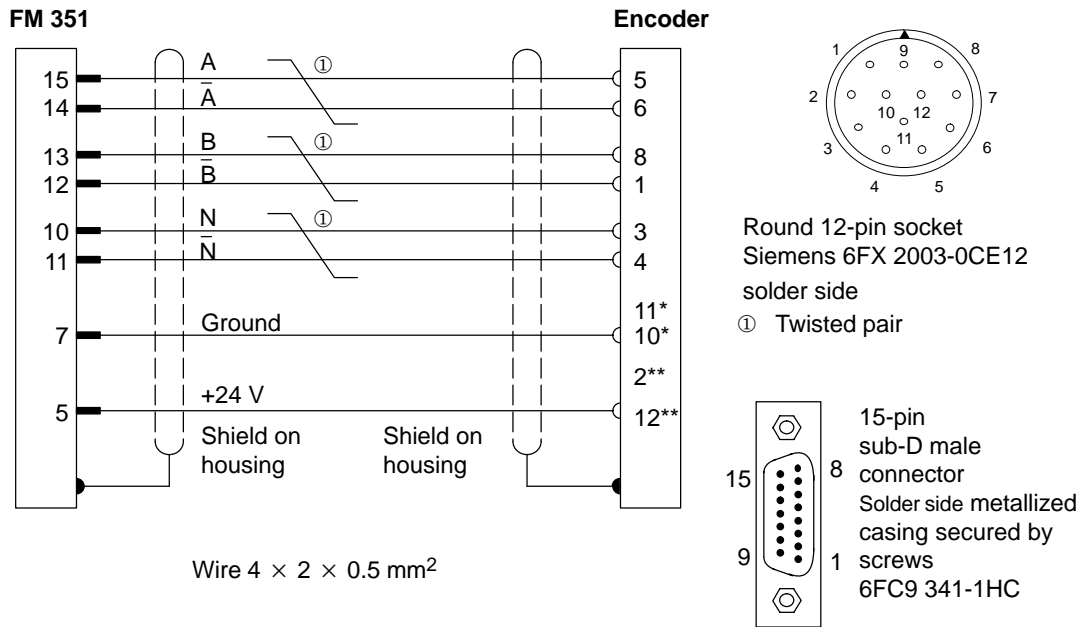

* Pins 10 and 11 are jumpered internally.

** Pins 2 and 12 are jumpered internally.

B.3 Connection Diagram for Incremental Encoder Siemens 6FX 2001-4 (Up=24V; HTL)

Connection Diagram

The following illustration shows the connecting diagram for the incremental encoder Siemens 6FX 2001-4 (Up=24 V; HTL):

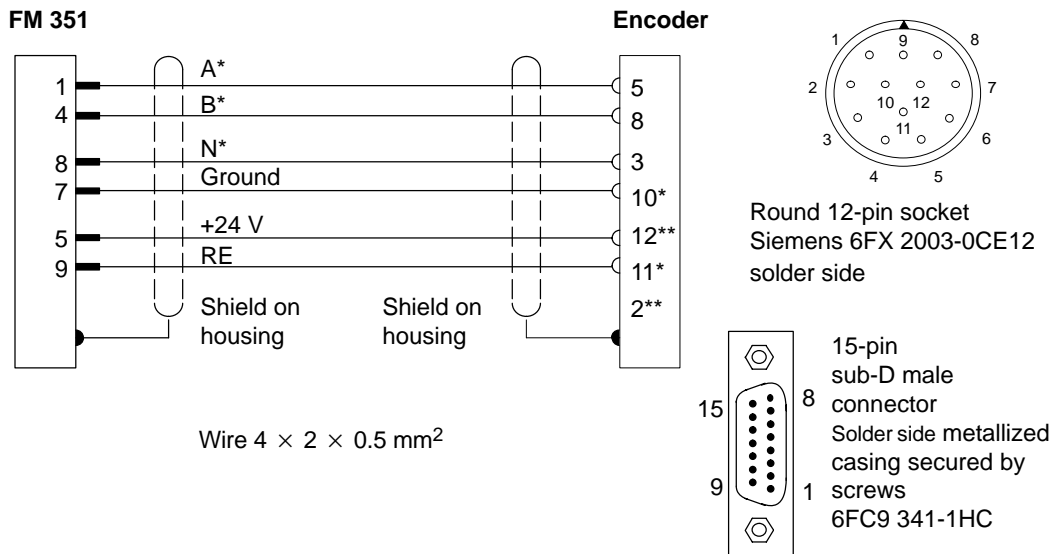

* Pins 10 and 11 are jumpered internally.

** Pins 2 and 12 are jumpered internally.

Note

If you would like to connect an incremental encoder from another manufacturer in a push-pull configuration (current sourcing/sinking), then you must observe the following:

- Current sourcing: Connect RE (9) to ground (7).
- Current sinking: Connect RE (9) to +24 V (5).

B.4 Connection Diagram for Absolute Encoder Siemens 6FX 2001-5 (Up=24V; SSI)

Connection Diagram

The following illustration shows the connecting diagram for the absolute encoder Siemens 6FX 2001-5□□□□ (Up=24 V; SSI):

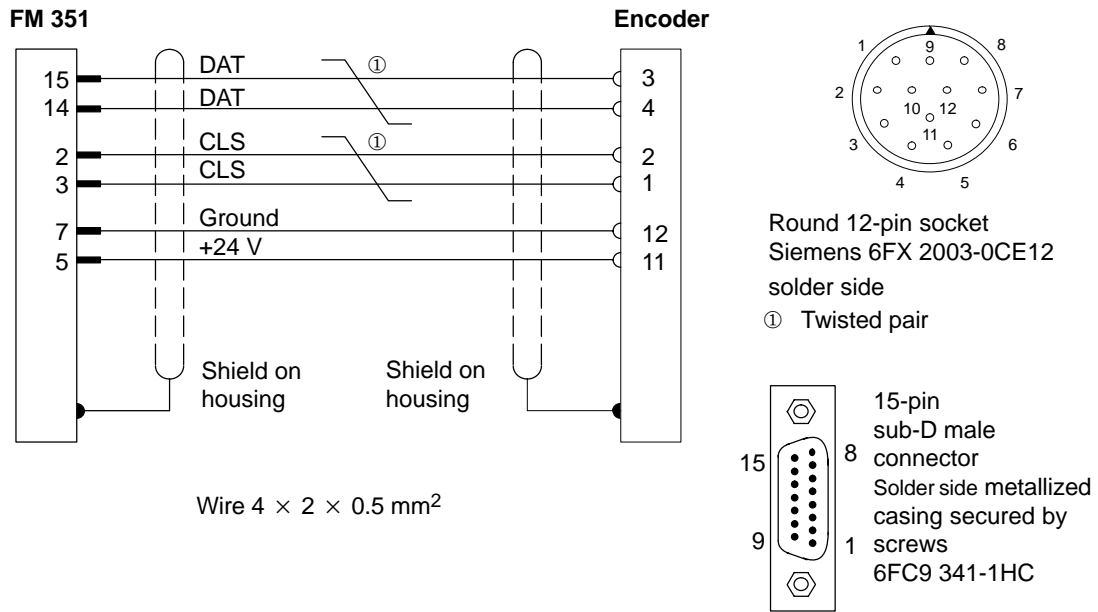

C

Data Blocks/Error Lists

Chapter Overview

Section	Topic	Page
C.1	Content of the Channel DB	C-2
C.2	Content of the Parameter DB	C-9
C.3	Data and Structure of the Diagnostic DB	C-11
C.4	List of JOB_ERR Messages	C-13
C.5	Error Classes	C-15

C.1 Content of the Channel DB

Note

Do not modify data that are not listed in this table.

Table C-1 Content of the Channel DB

Address	Name	Data Type	Initial Value	Description
Addresses				
0.0	MOD_ADDR	INT	0	Module address
2.0	CH_NO	INT	1	Channel number
10.0	PARADBNO	INT	-1	Number of the parameter DB
Control signals				
14.3	OT_ERR_A	BOOL	FALSE	1 = acknowledge operator error
15.0	START	BOOL	FALSE	1 = start positioning
15.1	STOP	BOOL	FALSE	1 = stop currently active traverse
15.2	DIR_M	BOOL	FALSE	1 = direction minus
15.3	DIR_P	BOOL	FALSE	1 = direction plus
15.6	SPEED252	BOOL	FALSE	Not used
15.7	DRV_EN	BOOL	FALSE	1 = enable drive on
16.0	MODE_IN	BYTE	B#16#0	Requested mode: 0 = no mode 1 = jogging 3 = reference point approach 4 = relative incremental mode 5 = absolute incremental mode
17.0	MODE_TYPE	BYTE	B#16#0	<ul style="list-style-type: none"> • Start speed for the jogging mode <ul style="list-style-type: none"> 0 = creep speed 1 = rapid speed • Incremental dimension number for the incremental approach mode

Table C-1 Content of the Channel DB

Address	Name	Data Type	Initial Value	Description
Return Signals				
22.2	DIAG	BOOL	FALSE	1 = diagnostic buffer changed
22.3	OT_ERR	BOOL	FALSE	1 = operator error occurred
22.4	DATA_ERR	BOOL	FALSE	1 = data error
22.7	PARA	BOOL	FALSE	1 = axis has parameters
23.0	ST_ENBLD	BOOL	FALSE	1 = start enabled
23.1	WORKING	BOOL	FALSE	1 = positioning active
23.2	WAIT_EI	BOOL	FALSE	1 = axis waiting for ext. enable
23.4	SPEED_OUT	BOOL	FALSE	0 = creep speed 1 = rapid speed
23.5	ZSPEED	BOOL	FALSE	1 = axis is in stationary range
23.6	CUTOFF	BOOL	FALSE	1 = axis is located in switch-off range
23.7	CHGOVER	BOOL	FALSE	1 = axis is located in switchover range
24.0	MODE_OUT	BYTE	B#16#0	Active mode
25.0	SYNC	BOOL	FALSE	1 = axis is synchronized.
25.1	MSR_DONE	BOOL	FALSE	Not used
25.2	GO_M	BOOL	FALSE	1 = axis traveling in minus direction
25.3	GO_P	BOOL	FALSE	1 = axis traveling in plus direction
25.5	FVAL_DONE	BOOL	FALSE	Not used
25.7	POS_RCD	BOOL	FALSE	1 = position reached
26.0	ACT_POS	DINT	L#0	Actual position (actual position of the axis)
Function Switches				
34.0	PLOOP_ON	BOOL	FALSE	1 = loop traverse in plus direction
34.1	MLOOP_ON	BOOL	FALSE	1 = loop traverse in minus direction
34.2	EI_OFF	BOOL	FALSE	1 = do not evaluate enable input
34.3	EDGE_ON	BOOL	FALSE	Not used
34.4	MSR_ON	BOOL	FALSE	Not used

Table C-1 Content of the Channel DB

Address	Name	Data Type	Initial Value	Description
Trigger Bits for Write Jobs				
35.0	MDWR_EN	BOOL	FALSE	1 = write machine data
35.1	MD_EN	BOOL	FALSE	1 = activate machine data
35.2	DELDIST_EN	BOOL	FALSE	1 = delete remaining distance
35.3	AVALREM_EN	BOOL	FALSE	1 = cancel set actual value
35.4	TRGL1WR_EN	BOOL	FALSE	1 = write incremental dimension table 1 (incremental dimension number 1 to 50)
35.5	TRGL2WR_EN	BOOL	FALSE	1 = write incremental dimension table 2 (incremental dimension number 51 to 100)
35.6	REFPT_EN	BOOL	FALSE	1 = set reference point
35.7	AVAL_EN	BOOL	FALSE	1 = set actual value.
36.0	FVAL_EN	BOOL	FALSE	Not used
36.1	ZOFF_EN	BOOL	FALSE	Not used
36.2	TRG252_254_EN	BOOL	FALSE	1 = write incremental dimension for incremental dimension number 254
36.3	TRG255_EN	BOOL	FALSE	1 = write incremental dimension for incremental dimension number 255
36.4	DELDIAG_EN	BOOL	FALSE	1 = delete diagnostic buffer
Trigger Bits for Read Jobs				
36.5	MDRD_EN	BOOL	FALSE	1 = read machine data
36.6	TRGL1RD_EN	BOOL	FALSE	1 = read incremental dimension table 1 (incremental dimension number 1 to 50)
36.7	TRGL2RD_EN	BOOL	FALSE	1 = read incremental dimension table 2 (incremental dimension number 51 to 100)
37.0	MSRRD_EN	BOOL	FALSE	Not used
37.1	ACTSPD_EN	BOOL	FALSE	1 = read actual speed, remaining distance and current incremental dimension
37.2	ENCVAL_EN	BOOL	FALSE	1 = read encoder values
Done Bits for Function Switches				
38.0	PLOOP_D	BOOL	FALSE	1 = "loop traverse in direction plus" job completed
38.1	MLOOP_D	BOOL	FALSE	1 = "loop traverse in direction minus" job completed
38.2	EI_D	BOOL	FALSE	1 = "do not evaluate enable input" job completed
38.3	EDGE_D	BOOL	FALSE	Not used
38.4	MSR_D	BOOL	FALSE	Not used

Table C-1 Content of the Channel DB

Address	Name	Data Type	Initial Value	Description
Done Bits for Write Jobs				
39.0	MDWR_D	BOOL	FALSE	1 = "write machine data" job completed
39.1	MD_D	BOOL	FALSE	1 = "activate machine data" job completed
39.2	DELDIST_D	BOOL	FALSE	1 = "delete remaining distance" job completed
39.3	AVALREM_D	BOOL	FALSE	1 = "cancel set actual value" job completed
39.4	TRGL1WR_D	BOOL	FALSE	1 = "write incremental dimension table 1" job completed
39.5	TRGL2WR_D	BOOL	FALSE	1 = "write incremental dimension table 2" job completed
39.6	REFPT_D	BOOL	FALSE	1 = "set reference point" job completed
39.7	AVAL_D	BOOL	FALSE	1 = "set actual value" job completed
40.0	FVAL_D	BOOL	FALSE	Not used
40.1	ZOFF_D	BOOL	FALSE	Not used
40.2	TRG252_254_D	BOOL	FALSE	1 = "write incremental dimension for incremental dimension number 254" completed
40.3	TRG255_D	BOOL	FALSE	1 = "write incremental dimension for incremental dimension number 255" completed
40.4	DELDIAG_D	BOOL	FALSE	1 = "delete diagnostic buffer" job completed
Done Bits for Read Jobs				
40.5	MDRD_D	BOOL	FALSE	1 = "read machine data" job completed
40.6	TRGL1RD_D	BOOL	FALSE	1 = "read incremental dimension table 1" job completed
40.7	TRGL2RD_D	BOOL	FALSE	1 = "read incremental dimension table 2" job completed
41.0	MSRRD_D	BOOL	FALSE	Not used
41.1	ACTSPD_D	BOOL	FALSE	1 = "read actual speed, remaining distance and current incremental dimension" job completed
41.2	ENCVAL_D	BOOL	FALSE	1 = "read encoder values" job completed

Table C-1 Content of the Channel DB

Address	Name	Data Type	Initial Value	Description
Error Bits for Function Switches				
42.0	PLOOP_ERR	BOOL	FALSE	1 = error in "loop traverse in direction plus" job
42.1	MLOOP_ERR	BOOL	FALSE	1 = error in "loop traverse in direction minus" job
42.2	EI_ERR	BOOL	FALSE	1 = error in "Do not evaluate enable input" job
42.3	EDGE_ERR	BOOL	FALSE	Not used
42.4	MSR_ERR	BOOL	FALSE	Not used
Error Bits for Write Jobs				
43.0	MDWR_ERR	BOOL	FALSE	1 = error in "write machine data" job
43.1	MD_ERR	BOOL	FALSE	1 = error in "activate machine data" job
43.2	DELDIST_ERR	BOOL	FALSE	1 = error in "deleted remaining distance" job
43.3	AVALREM_ERR	BOOL	FALSE	1 = error in "cancel set actual value" job
43.4	TRGL1WR_ERR	BOOL	FALSE	1 = error in "write incremental dimension table 1" job
43.5	TRGL2WR_ERR	BOOL	FALSE	1 = error in "write incremental dimension table 2" job
43.6	REFPT_ERR	BOOL	FALSE	1 = error in "set reference point" job
43.7	AVAL_ERR	BOOL	FALSE	1 = error in "cancel set actual value" job
44.0	FVAL_ERR	BOOL	FALSE	Not used
44.1	ZOFF_ERR	BOOL	FALSE	Not used
44.2	TRG252_254_ERR	BOOL	FALSE	1 = error in "write incremental dimension for incremental dimension number 254" job
44.3	TRG255_ERR	BOOL	FALSE	1 = error in "write incremental dimension for incremental dimension number 255" job
44.4	DELDIAG_ERR	BOOL	FALSE	1 = error in "delete diagnostic buffer" job

Table C-1 Content of the Channel DB

Address	Name	Data Type	Initial Value	Description
Error Bits for Read Jobs				
44.5	MDRD_ERR	BOOL	FALSE	1 = error in "read machine data" job
44.6	TRGL1RD_ERR	BOOL	FALSE	1 = error in "read incremental dimension table 1" job
44.7	TRGL2RD_ERR	BOOL	FALSE	1 = error in "read incremental dimension table 2" job
45.0	MSRRD_ERR	BOOL	FALSE	Not used
45.1	ACTSPD_ERR	BOOL	FALSE	1 = error in "read actual speed, remaining distance and current incremental dimension" job
45.2	ENCVAL_ERR	BOOL	FALSE	1 = error in "read current encoder values" job
Job Management for FC ABS_CTRL				
48.0	JOB_ERR	INT	0	Error number of the communication error
50.0	JOBBUSY	BOOL	FALSE	1 = at least one job active
50.1	JOBRESET	BOOL	FALSE	1 = reset all error and done bits
Data for "zero offset" job (FM 451)				
80.0	ZOFF	DINT	L#0	Not used
Data for "Set Actual Value" Job				
84.0	AVAL	DINT	L#0	Coordinate for "set actual value"
Data for "set actual value on-the-fly" job (FM 451)				
88.0	FVAL	DINT	L#0	Not used
Data for "Set Reference Point" job				
92.0	REFPT	DINT	L#0	Coordinate for "set reference point"
Data for "write incremental dimension for incremental dimension number 254"				
96.0	TRG252_254	DINT	L#0	Incremental dimension for incremental dimension number 254
Data for "write incremental dimension for incremental dimension number 255" job				
100.0	TRG255	DINT	L#0	Incremental dimension for incremental dimension number 255
104.0	CHGDIF255	DINT	L#0	Switchover difference for incremental dimension number 255
108.0	CUTDIF255	DINT	L#0	Switch-off difference for incremental dimension number 255
Data for "read position data" job				
112.0	ACTSPD	DINT	L#0	Current speed
116.0	DIST_TO_GO	DINT	L#0	Residual distance
120.0	ACT_TRG	DINT	L#0	Current incremental dimension
Data for the "Read Encoder Data" Job				
124.0	ENCVAL	DINT	L#0	Encoder actual value (internal representation)

Table C-1 Content of the Channel DB

Address	Name	Data Type	Initial Value	Description
Data for the "Read Encoder Data" Job				
128.0	ZEROVAL	DINT	L#0	Last zero marker value (internal representation)
132.0	ENC_ADJ	DINT	L#0	Absolute encoder adjustment
Data for "length measurement/edge detection" job (FM 451)				
136.0	BEG_VAL	DINT	L#0	Not used
140.0	END_VAL	DINT	L#0	Not used
144.0	LEN_VAL	DINT	L#0	Not used

C.2 Content of the Parameter DB

Note

Do not modify data that are not listed in this table.

Table C-2 Content of the Parameter DB

Address	Name	Data Type	Initial Value	Description
Machine data				
4.0	EDGEDIST	DINT	L#0	Not used
8.0	UNITS	DINT	L#1	System of Units
12.0	AXIS_TYPE	DINT	L#0	0 = linear axis 1 = rotary axis
16.0	ENDROTAX	DINT	L#100000	End of rotary axis
20.0	ENC_TYPE	DINT	L#1	Encoder type, frame length
24.0	DISP_REV	DINT	L#80000	Displacement per encoder rev.
32.0	INC_REV	DINT	L#500	Increments per encoder rev.
36.0	NO_REV	DINT	L#1	Number of encoder revolutions
40.0	BAUDRATE	DINT	L#0	Baud Rate
44.0	REFPT	DINT	L#0	Reference-point coordinate
48.0	ENC_ADJ	DINT	L#0	Absolute encoder adjustment
52.0	REFPT_TYPE	DINT	L#0	Type of reference point approach
59.0	CNT_DIR	BOOL	FALSE	Count direction: 0 = normal 1 = inverted
63.0	MON_WIRE	BOOL	TRUE	1 = wire break monitoring
63.1	MON_FRAME	BOOL	TRUE	1 = frame error monitoring
63.2	MON_PULSE	BOOL	TRUE	1 = missing pulse monitoring
64.0	SSW_STRT	DINT	L#-100000000	Software start limit switch
68.0	SSW_END	DINT	L#100000000	Software end limit switch
76.0	TRG_RANGE	DINT	L#1000	Target range
80.0	MON_TIME	DINT	L#2000	Monitoring time [ms]
84.0	ZSPEED_R	DINT	L#1000	Stationary range
88.0	ZSPEED_L	DINT	L#30000	Upper limit of stationary speed
92.0	CTRL_TYPE	DINT	L#1	Control mode (1 – 4)
99.0	REFPT_SPD	BOOL	TRUE	Start speed for reference point approach 0 = rapid speed 1 = creep speed
99.1	EI_TYPE	BOOL	FALSE	Not used

Table C-2 Content of the Parameter DB

Address	Name	Data Type	Initial Value	Description
Machine data				
100.0	CHGDIF_P	DINT	L#5000	Switchover difference plus
104.0	CHGDIF_M	DINT	L#5000	Switchover difference minus:
108.0	CUTDIF_P	DINT	L#2000	Switch-off difference plus
112.0	CUTDIF_M	DINT	L#2000	Switch-off difference minus
Incremental dimension table 1				
120.0	TRGL1.TRG[1]	DINT	L#0	Incremental dimension number 1
.	.	.	.	Incremental dimension table 1
316.0	TRGL1.TRG[50]	DINT	L#0	Incremental dimension number 50
Incremental dimension table 2				
320.0	TRGL2.TRG[51]	DINT	L#0	Incremental dimension number 51
.	.	.	.	Incremental dimension table 2
516.0	TRGL2.TRG[100]	DINT	L#0	Incremental dimension number 100

C.3 Data and Structure of the Diagnostic DB

Note

Do not modify data that are not listed in this table.

Table C-3 Structure of the Diagnostic DB

Address	Name	Data Type	Initial Value	Description
0.0	MOD_ADDR	INT	0	Module address
256.0	JOB_ERR	INT	0	Error number of the communication error
258.0	JOBBUSY	BOOL	FALSE	1 = job active
258.1	DIAGRD_EN	BOOL	FALSE	1 = read diagnostic buffer unconditional
260.0	DIAG_CNT	INT	0	Number of valid entries in the list
262.0	DIAG[1]	STRUCT		Diagnostic data latest entry
272.0	DIAG[2]	STRUCT		Diagnostic data second entry
282.0	DIAG[3]	STRUCT		Diagnostic data third entry
292.0	DIAG[4]	STRUCT		Diagnostic data fourth entry
302.0	DIAG[5]	STRUCT		Diagnostic data fifth entry
312.0	DIAG[6]	STRUCT		Diagnostic data sixth entry
322.0	DIAG[7]	STRUCT		Diagnostic data seventh entry
332.0	DIAG[8]	STRUCT		Diagnostic data eighth entry
342.0	DIAG[9]	STRUCT		Diagnostic data ninth entry

The diagnostic entry DIAG[n] is structured as follows:

Table C-4 Structure of the Diagnostic Entry

Address	Name	Data Type	Initial Value	Description
+0.0	STATE	BOOL	FALSE	0 = event leaving state 1 = event entering state
+0.1	INTF	BOOL	FALSE	1 = internal error
+0.2	EXTF	BOOL	FALSE	1 = external error
+2.0	FCL	INT	0	Error class: 1: Operating errors 2: Operating errors. 4: data error 5: Machine data errors 6: Incremental dimension table error 15: Messages 128: Diagnostic errors
+4.0	FNO	INT	0	Fault number
+6.0	CH_NO	INT	0	Channel number
+8.0	TRG_NO	INT	0	Increment number

C.4 List of JOB_ERR Messages

JOB_ERR (hex)	JOB_ERR (dec)	JOB_ERR (int)	Meaning
80A0	32928	-32608	Negative acknowledgment when reading from module. Module removed during read operation or module defective.
80A1	32929	-32607	Negative acknowledgment when writing to module. Module removed during write operation or module defective.
80A2	32930	-32606	DP protocol error at layer 2
80A3	32931	-32605	DP protocol error at user interface / user
80A4	32932	-32604	Communication problem on K bus
80B0	32944	-32592	Data record/job unknown.
80B1	32945	-32591	Specified length wrong. Incorrectly set FM_TYPE parameter in the channel DB for the module in use.
80B2	32946	-32590	The configured slot is empty.
80B3	32947	-32589	Actual module type does not match configured module type.
80C0	32960	-32576	The module does not have the data to be read.
80C1	32961	-32575	The data of a write job of the same type have not yet been processed on the module.
80C2	32962	-32574	The module is currently processing the maximum number of jobs.
80C3	32963	-32573	Required resources (memory etc.) currently in use.
80C4	32964	-32572	Communication error
80C5	32965	-32571	Distributed I/Os not available.
80C6	32966	-32570	Priority class abort (warm restart or background)
8522	34082	-31454	Channel DB or parameter DB too short. The data cannot be read from the DB. (write job)
8532	34098	-31438	DB number of the parameter DB too high. (write job)
853A	34106	-31430	Parameter DB does not exist. (write job)
8544	34116	-31420	Error in nth ($n > 1$) read access to a DB after error occurred. (write job)
8723	34595	-30941	Channel DB or parameter DB too short. The data cannot be written to the DB. (read job)
8730	34608	-30928	Parameter DB on the CPU write-protected. The data cannot be written to the DB (read job).
8732	34610	-30926	DB number of the parameter DB too high. (read job)
873A	34618	-30918	Parameter DB does not exist. (read job)

8745	34629	-30907	Error in nth ($n > 1$) write access to a DB after error occurred. (read job)
The errors 80A2 to 80A4 and 80Cx are temporary; in other words, they can be cleared after a waiting time without you taking any action.			

C.5 Error Classes

Class 1: Operating Errors

Operating errors are detected asynchronous to operator input/commands. The operating errors lead to the positioning being aborted, except for error number 9. This leads to the positioning being terminated.

No.	Meaning	Diagnostic Interrupt
1	Software limit switch start passed	Yes
	Cause The actual value is outside the working range.	
2	Software limit switch end passed	Yes
	Cause The actual value is outside the working range.	
3	Travel range start passed	Yes
	Cause Limit of traverse range passed (the coordinates of the traverse range limits are included in the traverse range)	
4	Travel range end passed	Yes
	Cause Limit of traverse range passed (the coordinates of the traverse range limits are included in the traverse range)	
5	Error in final target approach.	Yes
	Cause Target range was not reached within the monitoring time	
6	Stationary range left.	Yes
	Cause The actual value is outside the stationary range.	
7	Positive feedback.	Yes
	Cause Actual value change > 1/2 stationary range in the wrong direction.	
8	No change in actual value or change too small	Yes
	Cause There is no actual value change or the actual value change is against the programmed direction within the monitoring time.	
9	Target passed (FM 451)	Yes
	Cause The target was passed during "set actual value on-the-fly"	
10	Target range passed.	Yes
	Cause Target range was passed after the final target approach.	
11	Switchover point incorrectly switched.	Yes
	Cause Axis oscillating at the switchover point.	
12	Switch-off point incorrectly switched.	Yes
	Cause Axis oscillating at the switch-off/reversal point.	
13	Start of target range incorrectly switched.	Yes
	Cause Axis oscillating in the target range.	

No.	Meaning	Diagnostic Interrupt
14	Change greater than the half rotary axis range	Yes
	Cause The speed/frequency is too high or there are incorrect sudden changes in the actual value.	
15	Change greater than rotary axis range	Yes
	Cause The speed/frequency is too high or there are incorrect sudden changes in the actual value.	
16	Incremental dimension for incremental dimension number 252 not transferred (FM 451)	Yes
	Cause The incremental dimension was not transferred.	
17	Approach to incremental dimension for incremental dimension number 252 not possible (FM 451)	Yes
	Cause The distance between the current actual position and the specified incremental dimension is less than the switchover difference or switch-off distance.	
18	Wrong incremental dimension for incremental dimension number 252 (FM 451)	Yes
	Cause The incremental dimension is outside the working range.	

Class 2: Operator Errors

Operator errors are detected when the control signals are modified in the user data area. Operator errors lead to the positioning being terminated.

No.	Meaning	Diagnostic Interrupt
1	Illegal operating mode	no
	Cause The selected operating mode is illegal.	
3	Illegal interface job	no
	Cause The selected signal is illegal with this operating mode	
4	Incorrect mode parameter	no
	Cause <ul style="list-style-type: none"> • In the "Jogging" mode, the speed specified is not equal to the rapid speed or the creep speed • In the "incremental approach" mode, the incremental dimension is not equal to 1 to 100 or not equal to 254 and 255 	
5	No start enable	no
	Cause No start enable when starting.	
7	Target/target range outside working range	no
	Cause Specified or calculated target outside the software limit switches.	
8	Parameters not set for the axis	no
	Cause Incorrect or no machine data were set for the axis	

No.	Meaning	Diagnostic Interrupt
9	Axis not synchronized	no
	Cause	
10	Target/distance cannot be positioned	no
	Cause	
17	Reference point approach not possible	no
	Cause	
18	Relative or absolute incremental approach not possible	no
	Cause	
19	Switch-off difference not greater than 1/2 target range for incremental dimension number 255	no
	Cause	
20	Travel in specified direction illegal	no
	Cause	

Class 4: Data Errors

Data errors are detected synchronous to operator input/commands. Data errors do not lead to an error reaction.

No.	Meaning	Diagnostic Interrupt
6	Specified increment too large	No
	Cause	
10	Bad zero offset (FM 451)	No
	Cause	

No.	Meaning		Diagnostic Interrupt
11	Incorrect actual value specified		No
	Cause	Linear axis: the coordinate is outside the current (possibly shifted) software limit switch. Rotary axis: The coordinate is < 0 or higher than the end of the rotary axis.	
12	Incorrect reference point		No
	Cause	Linear axis: the coordinate is outside the current (possibly shifted) software limit switch. Rotary axis: The coordinate is < 0 or higher than the end of the rotary axis.	
20	Activate machine data not permitted		No
	Cause	There are no new (error-free) machine data on the module	
27	Illegal bit-coded setting		No
	Cause	Unused and, in this case, unwritten bits are not 0.	
29	Illegal bit coding		No
	Cause	Unused and, in this case, unwritten bits are not 0.	
34	Cancel set actual value not possible		No
	Cause	The actual position value would be outside the working range with an SSI encoder and a linear axis after making the setting.	
36	Incorrect switchover difference in incr. dim. no. 255		No
	Cause	The value is not within the permitted numeric range of ± 100 m or ± 1000 m. On a rotary axis, the coordinate must be ≥ 0 and less than the end of the rotary axis.	
37	Incorrect switch-off difference in incr. dim. no. 255		No
	Cause	The value is not within the permitted numeric range of ± 100 m or ± 1000 m. The switch-off difference must be smaller than the switchover difference.	
107	Parameters not set for the axis		No
	Cause	Either there are no machine data on the axis or they are not activated.	
108	Axis not synchronized		No
	Cause	One of the jobs "set actual value" or "set actual value on-the-fly" was started although the axis is not synchronized.	

Class 5: Machine Data Errors

The diagnostic interrupt is triggered only when there is an error in the system data block (SDB). Data machine data do not lead to an error reaction.

No.	Meaning	Diagnostic Interrupt
5	Error in hardware interrupt setting	Yes
	Cause	
6	Wrong minimum edge-to-edge distance (FM 451)	Yes
	Cause	
7	Wrong system of units	Yes
	Cause	
8	Incorrect axis type	Yes
	Cause	
9	Incorrect rotary axis end	Yes
	Cause	
10	Incorrect encoder type	Yes
	Cause	
11	Incorrect distance per encoder revolution	Yes
	Cause	
13	Incorrect increments per encoder revolution (see Section 8.5, page 8-15)	Yes
14	Incorrect number revolutions (see Section 8.5, page 8-15)	Yes
15	Incorrect baud rate	Yes
	Cause	
16	Incorrect reference point coordinate	Yes
	Cause	

No.	Meaning		Diagnostic Interrupt
17	Incorrect absolute encoder adjustment		Yes
	Cause	SSI encoder: The value of the absolute encoder adjustment is not in the encoder range (increments per encoder revolution × number of revolutions – 1).	
18	Incorrect reference point approach type		Yes
	Cause	You have specified a value other than 0, 1, 2 and 3.	
19	Incorrect count direction		Yes
	Cause	You have specified a value other than 0 and 1.	
20	Hardware monitoring not possible		Yes
	Cause	You have set the monitoring of frame errors in the parameter DB to "FALSE".	
21	Incorrect software limit switch start		Yes
	Cause	Linear axis: The software limit switch start is outside the travel range (–100m...+100m or –1000m...+1000m, depending on the resolution). Linear axis: The software limit switch start (possibly including any zero offset) is less than –100 m or –1000 m (depending on the resolution).	
22	Incorrect software limit switch end		Yes
	Cause	Linear axis: The software limit switch end is outside the travel range (–100m...+100m or –1000m...+1000m, depending on the resolution) or is less than the software limit switch start. Linear axis: The software limit switch end (including any existing zero offset) is higher than +100 m or +1000 m (depending on the resolution).	
23	Incorrect maximum speed		Yes
	Cause	The data not listed in the parameter DB must be 0.	
24	Incorrect target range		Yes
	Cause	Linear axis: Range between 0 and 100 m or 1000 m, depending on the resolution. Rotary axis Range greater than the end of the rotary axis.	
25	Incorrect monitoring time		Yes
	Cause	The value for the monitoring time is outside the permitted range of 0 to 100 000ms.	
26	Incorrect stationary range		Yes
	Cause	Linear axis: Range between 0 and 100 m or 1000 m, depending on the resolution. Rotary axis Range greater than the end of the rotary axis.	

No.	Meaning	Diagnostic Interrupt
127	Incorrect stationary speed	Yes
	Cause The value for the stationary speed is outside the permitted range of 0 to 100 000µm/min.	
128	Incorrect control mode	Yes
	Cause You have specified a control mode outside the permitted range of 1 to 4.	
129	Incorrect start speed for reference point approach	Yes
	Cause You have specified neither 0 nor 1 as the start speed.	
130	Incorrect switchover difference in direction +	Yes
	Cause Linear axis: Range between 0 and 100 m or 1000 m, (depending on the resolution). Rotary axis Range greater than the end of the rotary axis and less than 1/2 the target range	
131	Incorrect switchover difference in direction –	Yes
	Cause Linear axis: Range between 0 and 100 m or 1000 m, (depending on the resolution). Rotary axis Range greater than the end of the rotary axis and less than 1/2 the target range	
132	Incorrect switch-off difference in direction +	Yes
	Cause The switch-off difference is greater than the switchover difference plus, less than 1/2 the target range, or is outside the permitted range between 0 and 100 m or 1000 m (depending on the resolution).	
133	Incorrect switch-off difference in direction –	Yes
	Cause The switch-off difference is greater than the switchover difference minus, less than 1/2 the target range, or is outside the permitted range between 0 and 100 m or 1000 m (depending on the resolution).	
200	Incorrect resolution	Yes
	Cause You have specified a resolution < 0.1 µm/pulse or > 1000 µm/pulse. You have specified a distance/encoder revolution and a number of pulses/encoder revolution, that results in a resolution of < 0.1 or > 1000.	
201	Encoder does not match the working range / rotary axis range	Yes
	Cause SSI encoder and rotary axis: The encoder does not exactly cover the rotary axis range. Linear axis: The encoder does not cover at least the working range (incl. software limit switch).	

Class 6: Incremental Dimension Table Errors

The incremental dimension table errors do not lead to an error reaction.

No.	Meaning	Diagnostic Interrupt
6	Incremental dimension specified in the incremental dimension table too high	No
	Cause The value is outside ± 100 m or ± 1000 m. The distance/ target must be greater than the travel range On a rotary axis, the coordinate must be $> = 0$ and less than the end of the rotary axis.	

Class 15: Messages

Messages do not lead to an error reaction.

No.	Meaning	Diagnostic Interrupt
1	Start of parameter assignment	No
	Cause The module has detected a parameter assignment by a system data block.	
2	End of parameter assignment	No
	Cause The module has processed the parameter assignment by a system data block error-free.	
11	Not enough distance to switchover point	No
	Cause The hardware response times cannot be maintained since the interval between the switching points is too small.	
12	Not enough distance to reversal point	No
	Cause The hardware response times cannot be maintained since the interval between the switching points is too small.	
14	Not enough distance to switch-off point	No
	Cause The hardware response times cannot be maintained since the interval between the switching points is too small.	
15	Not enough distance to start of target range	No
	Cause The hardware response times cannot be maintained since the interval between the switching points is too small.	

Class 128: Diagnostic Errors

No.	Meaning	Diagnostic Interrupt	
4	External auxiliary voltage missing	Yes	
	Cause		<ul style="list-style-type: none"> External 24 V auxiliary supply is not connected or failed. Fuse on module defective Undervoltage Ground wire break
	Effect		<ul style="list-style-type: none"> Positioning is aborted on all channels Switching off the outputs Deletion of the synchronization for Incremental encoders if the auxiliary supply fails The FM 351 has not been assigned parameters. Start enable is deleted.
	Remedy		Make sure that the 24 V connection is correct. (If 24 V connection is correct, then the module is defective.)
50	Front connector missing (FM 451)	Yes	
	Cause		Front connector of the positioning module not inserted.
	Effect		<ul style="list-style-type: none"> No external 24 V auxiliary supply Module not ready for operation
	Remedy		Insert the front connector of the positioning module.
51	Watchdog tripped	Yes	
	Cause		<ul style="list-style-type: none"> Strong interference on the FM 351. Error in the FM 351.
	Effect		<ul style="list-style-type: none"> Module is reset. All outputs deactivated Provided that after resetting the module, no module defect is detected, the module is ready for operation again. The module signals the expired WATCHDOG with "entering state" and "leaving state".
	Remedy		<ul style="list-style-type: none"> Eliminate the interference. Contact the relevant sales department who will require details of the circumstances leading to the error. Replace the FM 351.

No.	Meaning	Diagnostic Interrupt						
144	<p data-bbox="446 319 716 348">Encoder wire breakage</p> <table border="1" data-bbox="446 359 1154 974"> <tr> <td data-bbox="446 367 576 638">Cause</td> <td data-bbox="576 367 1154 638"> <ul style="list-style-type: none"> • Encoder cable cut or not plugged in. • Encoder has no quadrature signals. • Incorrect pin assignment. • Cable length too long. • Encoder signals short circuited. • Encoder signal edge error • Maximum input frequency of the encoder input exceeded • Failure of the encoder supply. </td> </tr> <tr> <td data-bbox="446 638 576 800">Effect</td> <td data-bbox="576 638 1154 800"> <ul style="list-style-type: none"> • Positioning is aborted. • Switching off the outputs • With incremental encoders, synchronization is deleted. • Start enable is deleted. </td> </tr> <tr> <td data-bbox="446 800 576 974">Remedy</td> <td data-bbox="576 800 1154 974"> <ul style="list-style-type: none"> • Check encoder cable. • Keep within encoder specification. • Monitoring can be temporarily suppressed at the operator's risk by setting parameters in the parameter dialog. • Keep to the module technical data. </td> </tr> </table>	Cause	<ul style="list-style-type: none"> • Encoder cable cut or not plugged in. • Encoder has no quadrature signals. • Incorrect pin assignment. • Cable length too long. • Encoder signals short circuited. • Encoder signal edge error • Maximum input frequency of the encoder input exceeded • Failure of the encoder supply. 	Effect	<ul style="list-style-type: none"> • Positioning is aborted. • Switching off the outputs • With incremental encoders, synchronization is deleted. • Start enable is deleted. 	Remedy	<ul style="list-style-type: none"> • Check encoder cable. • Keep within encoder specification. • Monitoring can be temporarily suppressed at the operator's risk by setting parameters in the parameter dialog. • Keep to the module technical data. 	Yes
Cause	<ul style="list-style-type: none"> • Encoder cable cut or not plugged in. • Encoder has no quadrature signals. • Incorrect pin assignment. • Cable length too long. • Encoder signals short circuited. • Encoder signal edge error • Maximum input frequency of the encoder input exceeded • Failure of the encoder supply. 							
Effect	<ul style="list-style-type: none"> • Positioning is aborted. • Switching off the outputs • With incremental encoders, synchronization is deleted. • Start enable is deleted. 							
Remedy	<ul style="list-style-type: none"> • Check encoder cable. • Keep within encoder specification. • Monitoring can be temporarily suppressed at the operator's risk by setting parameters in the parameter dialog. • Keep to the module technical data. 							
145	<p data-bbox="446 991 729 1020">Absolute encoder errors</p> <table border="1" data-bbox="446 1031 1154 1635"> <tr> <td data-bbox="446 1039 576 1415">Cause</td> <td data-bbox="576 1039 1154 1415"> <p data-bbox="583 1039 1114 1115">Problems in frame exchange between the FM 351 and the absolute encoder (SSI) or exchange is interrupted:</p> <ul style="list-style-type: none"> • Encoder cable cut or not plugged in. • Incorrect encoder type • Encoder incorrectly set (programmable encoders) • Frame length incorrectly specified • Encoder supplies incorrect values (encoder defective) • Interference on measuring system cable • Baud rate selected too high • Monoflop time of the encoder greater than 64 μs </td> </tr> <tr> <td data-bbox="446 1415 576 1520">Effect</td> <td data-bbox="576 1415 1154 1520"> <ul style="list-style-type: none"> • Positioning is aborted. • Switching off the outputs • Start enable is deleted. </td> </tr> <tr> <td data-bbox="446 1520 576 1635">Remedy</td> <td data-bbox="576 1520 1154 1635"> <ul style="list-style-type: none"> • Check encoder cable. • Check the encoder. • Check the frame traffic between encoder and FM 351. </td> </tr> </table>	Cause	<p data-bbox="583 1039 1114 1115">Problems in frame exchange between the FM 351 and the absolute encoder (SSI) or exchange is interrupted:</p> <ul style="list-style-type: none"> • Encoder cable cut or not plugged in. • Incorrect encoder type • Encoder incorrectly set (programmable encoders) • Frame length incorrectly specified • Encoder supplies incorrect values (encoder defective) • Interference on measuring system cable • Baud rate selected too high • Monoflop time of the encoder greater than 64 μs 	Effect	<ul style="list-style-type: none"> • Positioning is aborted. • Switching off the outputs • Start enable is deleted. 	Remedy	<ul style="list-style-type: none"> • Check encoder cable. • Check the encoder. • Check the frame traffic between encoder and FM 351. 	Yes
Cause	<p data-bbox="583 1039 1114 1115">Problems in frame exchange between the FM 351 and the absolute encoder (SSI) or exchange is interrupted:</p> <ul style="list-style-type: none"> • Encoder cable cut or not plugged in. • Incorrect encoder type • Encoder incorrectly set (programmable encoders) • Frame length incorrectly specified • Encoder supplies incorrect values (encoder defective) • Interference on measuring system cable • Baud rate selected too high • Monoflop time of the encoder greater than 64 μs 							
Effect	<ul style="list-style-type: none"> • Positioning is aborted. • Switching off the outputs • Start enable is deleted. 							
Remedy	<ul style="list-style-type: none"> • Check encoder cable. • Check the encoder. • Check the frame traffic between encoder and FM 351. 							

No.	Meaning	Diagnostic Interrupt						
146	<p data-bbox="495 319 909 352">Incremental encoder missing pulses</p> <table border="1" data-bbox="487 357 1193 882"> <tr> <td data-bbox="495 367 617 577">Cause</td> <td data-bbox="617 367 1193 577"> <ul data-bbox="633 367 1185 567" style="list-style-type: none"> Encoder monitoring has detected missing pulses. Number of increments per encoder revolution is incorrectly entered. Encoder defective: Does not supply the specified number of pulses. Incorrect or missing zero marker. Interference affecting the encoder cable. </td> </tr> <tr> <td data-bbox="495 577 617 682">Effect</td> <td data-bbox="617 577 1193 682"> <ul data-bbox="633 577 933 672" style="list-style-type: none"> Positioning is aborted. Switching off the outputs Start enable is deleted. </td> </tr> <tr> <td data-bbox="495 682 617 882">Remedy</td> <td data-bbox="617 682 1193 882"> <ul data-bbox="633 682 1177 871" style="list-style-type: none"> Enter the number of increments/encoder revolution correctly (parameter dialog). Check the encoder and encoder cable. Keep to shielding and grounding regulations. Monitoring can be temporarily suppressed at the operator's risk by setting parameters in the parameter dialog. </td> </tr> </table>	Cause	<ul data-bbox="633 367 1185 567" style="list-style-type: none"> Encoder monitoring has detected missing pulses. Number of increments per encoder revolution is incorrectly entered. Encoder defective: Does not supply the specified number of pulses. Incorrect or missing zero marker. Interference affecting the encoder cable. 	Effect	<ul data-bbox="633 577 933 672" style="list-style-type: none"> Positioning is aborted. Switching off the outputs Start enable is deleted. 	Remedy	<ul data-bbox="633 682 1177 871" style="list-style-type: none"> Enter the number of increments/encoder revolution correctly (parameter dialog). Check the encoder and encoder cable. Keep to shielding and grounding regulations. Monitoring can be temporarily suppressed at the operator's risk by setting parameters in the parameter dialog. 	Yes
Cause	<ul data-bbox="633 367 1185 567" style="list-style-type: none"> Encoder monitoring has detected missing pulses. Number of increments per encoder revolution is incorrectly entered. Encoder defective: Does not supply the specified number of pulses. Incorrect or missing zero marker. Interference affecting the encoder cable. 							
Effect	<ul data-bbox="633 577 933 672" style="list-style-type: none"> Positioning is aborted. Switching off the outputs Start enable is deleted. 							
Remedy	<ul data-bbox="633 682 1177 871" style="list-style-type: none"> Enter the number of increments/encoder revolution correctly (parameter dialog). Check the encoder and encoder cable. Keep to shielding and grounding regulations. Monitoring can be temporarily suppressed at the operator's risk by setting parameters in the parameter dialog. 							

Index

A

Aborting, **9-7**
Aborting a reference point approach, 9-14
Aborting an incremental approach, 9-22
Aborting jogging, 9-9
Absolute encoder
 data transfer, 10-4
 frame run time, 10-5
 increments per encoder revolution, 8-16
 monoflop time, 10-5
 pulse evaluation, 10-4
 reaction times, 10-5
Absolute encoder adjustment, **8-19**
 alternative, 8-21
 finding, 8-19
Absolute encoders, **10-4**
Absolute incremental approach, 9-17, **9-18**,
 9-19
Actual monitoring time, 8-11
Addresses, C-2
Ambient temperature, 3-1
Area of application for SIMATIC, A-2
Asymmetric output signals, 10-2
Asynchronous errors, 11-2
Auxiliary power for encoder, 4-5
Auxiliary power for encoders, polarity, 4-5
Auxiliary power for load current, polarity, 4-5
Axis, machine data, **8-12**

B

Baud rate, 8-17
Block library, 6-2
Block templates, 6-2
Blocks, downloading to CPU, 7-5

C

Cable length, maximum, 8-17
Cancel set actual value, **9-23**
CE mark, A-1

Channel DB, 6-13
 preparing, 7-5
 structure, 6-13
 task, 6-13
CNT_DIR, 8-17
Configuration software, 7-3
Connecting cords, 4-9
Connecting encoders, 4-3
Connection diagrams, B-1
Control circuit, 4-7
Control mode, 4-6, **8-6**
Control signals, C-2
 writing, 6-18
Controlled positioning, **2-2**
Count direction, 8-17
CPU, startup, 6-8
Creating a project, 7-2

D

Data error, C-17
Data for "Activate incremental dimension 254"
 job, C-7
Data for "Activate incremental dimension 255"
 job, C-7
Data for "Read position data" job, C-7
Data for "set actual value" job, C-7
Data for "set reference point" job, C-7
Data for the "read encoder data" job, C-7
Delete remaining distance, **9-22**
Deleting the diagnostic buffer, 11-2
Diagnostic DB, 6-14
 preparing, 7-5
 structure, 6-14, C-11
 task, 6-14
Diagnostic error, C-23
Diagnostic interrupt, entering state, 11-12
Diagnostic interrupts, 11-11
 leaving state, 11-12
 overview, 11-11
 reaction of the FM 351, 11-11
Digital inputs, 4-6

Digital outputs, 4-6
Direct access to return signals, 6-17
Direction reversal, 9-28
DISP_REV, 8-15
Distance per encoder revolution, **8-15**
Do not evaluate enable input, **9-30**
Done bits for function switches, C-4
Done bits for read jobs, C-5
Done bits for write jobs, C-5
Drive, **8-6**

E

EMERGENCY OFF switch, 1-4
EMERGENCY STOP switch, 4-1, 7-1
Enable input, 4-4, 9-11, **9-30**
ENC_TYPE, 8-15
Encoder
 machine data, 8-15
 mechanical adjustment, 8-21
 multiturn, 10-4
 single-turn, 10-4
Encoder data, 9-32
 data used in the channel DB, 9-32
 requirements, 9-32
 sequence, 9-32
Encoder interface, 4-2
Encoder range, **8-14**
Encoder type, 8-15
Encoders, connecting, 4-3
End of positioning, 9-2
Error bits for function switches, C-6
Error bits for read jobs, C-7
Error bits for write jobs, C-6
Error classes, C-15
Error evaluation, 11-2
Error LEDs, 11-3
Execution times, 6-16

F

Fast access to module data, 6-17
FC ABS_CTRL, 6-5
 call, 6-5
 call parameters, 6-5
 data blocks used, 6-5
 response to errors, 6-9
 return values, 6-6
 tasks, 6-5

FC ABS_DIAG, 6-11
 call, 6-11
 call parameters, 6-11
 data block used, 6-11
 response to errors, 6-12
 return values, 6-12
 tasks, 6-11
FC ABS_INIT, 6-4
 call, 6-4
 call parameters, 6-4
 data block used, 6-4
 tasks, 6-4
FC0, FC ABS_INIT, 6-4
FC1, FC ABS_CTRL, 6-5
FC2, FC ABS_DIAG, 6-11
FCs and DBs, technical specifications, 6-15
Fictitious target, 9-28
FM 351
 installing, 3-2
 removing, 3-2
 startup, 6-8
FM 351, wiring, 4-1
Frame error, 8-18
Frame length, 8-15
Front connector
 pinout, 4-4
 wiring, 4-9
Function switch, C-3
Function switches, 6-6
Functions, 6-2
 execution times, 6-16

G

Ground connection, 4-10

H

Hardware installation, 7-2
Hardware limit switch, 7-1
Hardware limit switches, 4-1
Horizontal installation, 3-1

I

INC_REV, 8-16
Increment, 10-3

- Incremental approach mode
 - sequence with incremental dimension number 1–100, 9-18
 - sequence with incremental dimension number 254, 9-18
 - sequence with incremental dimension number 255, 9-19
- Incremental dimension number 1–100, 9-18
- Incremental dimension number 254, **8-25**, 9-18
- Incremental dimension number 255, **8-26**, 9-19
- Incremental dimension table errors, C-22
- Incremental dimension tables, writing, 8-3
- Incremental dimensions, 8-1, **8-24**
- Incremental encoder
 - increments per encoder revolution, 8-16
 - missing pulses, 8-18
 - reaction times, 10-3
 - signal shapes, 10-2
- Incremental encoders, **10-2**
- Incremental mode, **9-17**
- Increments per encoder revolution, 8-16
- Initial parameter assignment
 - incremental dimension tables, 8-3
 - machine data, 8-2
- Installation, 3-1, 3-2, 5-2
- Installation instructions, A-2
- Installation of the rail, 3-1
- Installing, 5-1
- Installing the configuration package, 5-1

J

- Job execution, order, 6-7
- Job management for FC ABS_CTRL, C-7
- Job status, 6-9
- Jobs, 6-6
- Jogging, **9-8**
- Jogging mode, sequence, 9-8

L

- LED "SF", 11-3
- LED CH 1, 11-3
- LED CH 2, 11-3
- Linear axis, **8-12**
- Load circuit, 4-7
- Load power supply, 4-5
- Location of the fictitious target, 9-28
- Loop traverse, **9-27**
 - sequence, 9-27

M

- Machine data, 8-1
 - activating, 8-2
 - axis, **8-12**
 - baud rate, 8-17
 - count direction, 8-17
 - distance per encoder revolution, 8-15
 - encoder, **8-15**
 - encoder type, 8-15
 - frame length, 8-15
 - increments per encoder revolution, **8-16**
 - monitoring functions, 8-18
 - number of encoder revolutions, 8-16
 - reading, 8-3
 - writing, 8-2
- Machine data error, C-19
- Machine data for the drive, 8-6
- Machine data of the encoder, data in the parameter DB, 8-15
- Mark, CE, iv
- Maximum cable length, 8-17
- Messages, C-22
- Missing pulses, incremental encoder, 8-18
- Modifying incremental dimension tables, 8-3
- Modifying machine data, 8-2
- Module cycle, 6-15
- Module data, fast access, 6-17
- MON_FRAME, 8-18
- MON_PULSE, 8-18
- MON_WIRE, 8-18
- Monitoring functions, **8-18**, 9-2
- Monitoring time, **8-11**, 9-3, 9-4, 9-5
- Motor circuit-breaker, 4-1
- Multiturn encoder, **10-4**, 10-4
 - frame length , range of values, 10-4

N

- NO_REV, 8-16

O

- Operating errors, C-15
- Operating mode incremental, 9-17
- Operating mode jogging, 9-8
- Operator errors, C-16
- Output signal
 - asymmetric, 10-2
 - symmetric, 10-2

P

- Parameter assignment, 7-3
- Parameter DB, C-9
 - areas, 6-14
 - structure, 6-14
 - task, 6-14
- Parameters relevant for synchronization, 8-4
- Pinout of the front connector, 4-4
- Polarity of the auxiliary power for encoder, 4-5
- Polarity of the auxiliary power for load current, 4-5
- Position data, data used in the channel DB, 9-31
- Positioning, end, 9-2
- Power unit, **4-7**
- Preparations for programming, 7-3
- Program structure, 6-10
- Programming, 6-1
- Pulses, **10-3**
- Putting into operation, 7-1

R

- Rail, 3-1
- Read position data, 9-31
 - sequence, 9-31
- Reading incremental dimension tables, 8-4
- Reference point, reproducibility, 9-12
- Reference point approach, **9-11**
- Reference point approach mode, 9-11
 - sequence, 9-11
- Reference speed, 8-10
- Reference-point switch, 4-4, 9-11
- Relative incremental approach, 9-17, **9-18**, **9-19**
- Remaining distance, **9-22**
- Removal, 3-2
- Reproducibility of a reference point, 9-12
- Resolution, **8-22**
 - calculation, 8-22
 - example, 8-23
 - range of values, 8-22
- Return signals, C-3
 - reading, 6-5, 6-17
- Return signals for diagnostics, 9-34
 - data used in the channel DB, 9-34
- Return signals for positioning
 - data used in the channel DB, 9-33
 - sequence, 9-33
- Reversing switch, 4-4, 9-11
- Rotary axis, **8-12**

S

- Safety concept, 4-1
- Safety-relevant switches, 7-2
- Samples, using, 12-3
- Set actual value, **9-23**
 - sequence, 9-23
- Set reference point, **9-25**
 - sequence, 9-25
- Shield contact element, 4-3
- Signal period, 10-3
- Single-turn encoder, **10-4**, 10-4
 - frame length , range of values, 10-4
- Slot, 3-1
- Software limit switch end, **8-14**
- Software limit switch start, **8-14**
- Standard system of units, 8-5
- Stationary range, 2-2, **8-10**
- Stationary speed, **8-10**
- Status LEDs, 11-3
- Step train frequency, 10-6
- Switch-off difference, **2-2**
- Switch-off difference minus, 8-9
- Switch-off difference plus, 8-9
- Switch-off point, **2-2**, 8-9
- Switches, relevant for safety, 7-2
- Switchover difference, **2-2**
- Switchover difference minus, 8-9
- Switchover difference plus, 8-9
- Switchover point, **2-2**, 8-9
- Symmetric output signals, 10-2
- Synchronization
 - reference point approach, **9-11**
 - set reference point, **9-25**
- Synchronous errors, 11-2

T

- Target, **2-2**
- Target approach, **9-3**
- Target range, **2-2**, 8-10
- Technical specifications, FM 351, 6-15
- Terminate, **9-6**
- Terminating an incremental approach, 9-22
- Terminating jogging, 9-9
- Total number of steps of the encoder, 8-16
- Travel range, **8-14**
 - relationship, 8-23
 - resolution, 8-23
- Trigger bits for read jobs, C-4
- Trigger bits for write jobs, C-4
- Type of reference point approach, 8-13, 9-15

Types of error, 11-2

U

Units, selecting, **8-5**

Unsharpness, 10-3, 10-6

W

Wire break, 8-18

Wiring, 4-1, 7-2

 front connector, 4-9

Wiring procedure, 4-9

WORKING, 9-2

Working range, 2-2, **8-14**

X

X1, 4-4

X2, 4-2

X3, 4-2

Siemens AG
A&D AS E 81

Oestliche Rheinbrueckenstr. 50
D-76181 Karlsruhe
Federal Republic of Germany

From:

Your Name: _____

Your Title: _____

Company Name: _____

Street: _____

City, Zip Code _____

Country: _____

Phone: _____

Please check any industry that applies to you:

- | | |
|--|---|
| <input type="checkbox"/> Automotive | <input type="checkbox"/> Pharmaceutical |
| <input type="checkbox"/> Chemical | <input type="checkbox"/> Plastic |
| <input type="checkbox"/> Electrical Machinery | <input type="checkbox"/> Pulp and Paper |
| <input type="checkbox"/> Food | <input type="checkbox"/> Textiles |
| <input type="checkbox"/> Instrument and Control | <input type="checkbox"/> Transportation |
| <input type="checkbox"/> Nonelectrical Machinery | <input type="checkbox"/> Other _____ |
| <input type="checkbox"/> Petrochemical | |



Remarks Form

Your comments and recommendations will help us to improve the quality and usefulness of our publications. Please take the first available opportunity to fill out this questionnaire and return it to Siemens.

Please give each of the following questions your own personal mark within the range from 1 (very good) to 5 (poor).

- 1. Do the contents meet your requirements?
- 2. Is the information you need easy to find?
- 3. Is the text easy to understand?
- 4. Does the level of technical detail meet your requirements?
- 5. Please rate the quality of the graphics/tables:

Additional comments:

